



MUSEUM

## **UNIQUE SURFACES**

Museum is a brand name synonymous with deluxe ceramic tiles. Its elegant sophisticated products stand out for their high-tech modern identity, with the emphasis on innovation, design and a forward looking vision.

We channel our experience as a manufacturer and desire to evolve into keeping abreast of today's times.

Thanks to the addition of new formats, textures and finishes, our range offers even broader design potential as part of our commitment to guaranteeing exquisite, highly desirable products with a clearly distinctive hallmark.

¿Qué puede hacer un usuario registrado  
en museumsurfaces.com?

—

## What can I do when I'm logged at museumsurfaces.com?

### 1. DOWNLOADS

- HD project pictures
- HD tiles images and patterns for 3d projects
- Tiles tech sheets

### 2. MARKETING

- Search and download catalogues
- Search and download promotional tools

### 3. INTRANET

- Check the stock in real time
- Packing info

### 4. 3D DESIGN

- Design your space with Museum product
- Render your project with HD quality

Visit our new website at  
[www.museumsurfaces.com](http://www.museumsurfaces.com)



Contacte con MUSEUM para conseguir su usuario y su contraseña  
Contact with MUSEUM to obtain your user and password

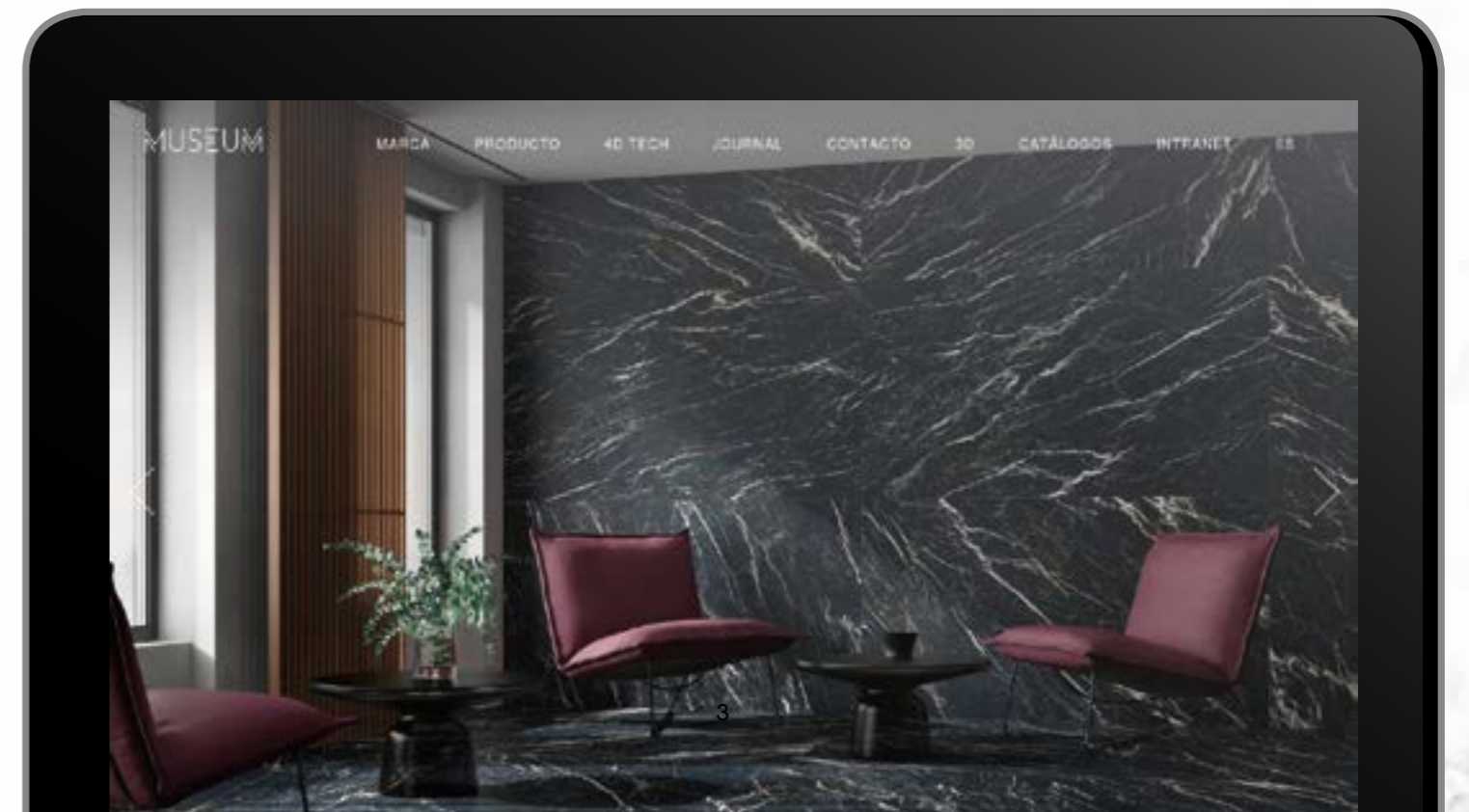



# MUSEUM



16	CALACATTA 4D	192	STATE
20	DEEP 4D	196	STIAVA
26	ETERNAL 4D	202	SUNSHINE
32	RUGBY	208	GREVIN
42	SOLTO	212	LENS
54	SHERWOOD OAK	222	LUMINA
62	BARDIGLIO	226	MARQ
74	GREYSTONE	230	MENHIR
83	MARQUINA	234	TUCCI
92	STATUARIO PLUS	242	VOGUE
105	BASATI	246	AGATHA
110	NARA	252	CAPITAL
118	ONIX	256	MACBA
124	SANTANA		MUVIM
128	SUITE	262	OPALO
138	TORANO		BACH
146	FIDIAS		ONICE
152	FREEZE		ZAR
156	GIOIA	268	PERSEPOLIS
162	HETTANGIAN FLOOR	274	PETRA
170	KRITIOS	280	LUXURY
176	MADISON	284	LED
182	METROPOLITAN FLOOR	288	CONCEPT
188	ORIO	294	BANSKY



↓  
8 mm — 0,31"  
↑

100 x 180 x 0,8 cm  
39,2 x 70,8 x 0,31 "

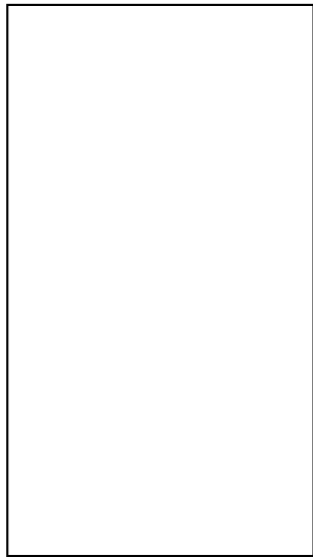

100 x 100 x 0,8 cm  
39,2 x 39,3 x 0,31 "

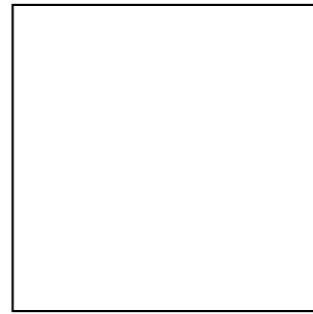

50 x 100 x 0,8 cm  
19,6 x 39,3 x 0,31 "

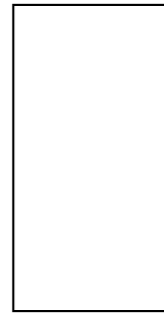

19,5 x 150 cm  
7,6 x 59 "



75,5x151 cm  
29,7x59,4"

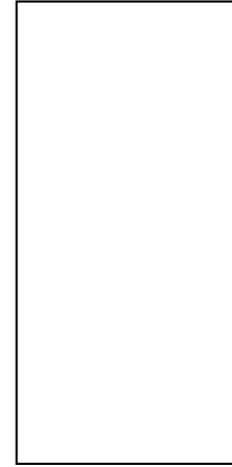

90x90 cm  
35,4x35,4"

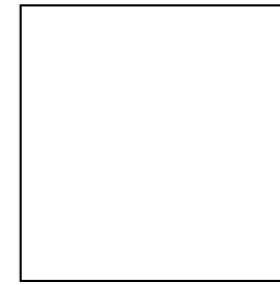

60x60 cm  
23,6x23,6"



44x44 cm  
17,3x17,3"



60x120 cm  
23,6x47,2"

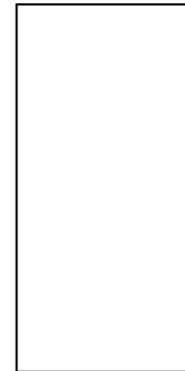

19,5x120 cm  
7,6x47,2 "



45x90 cm  
17,7x35,4"

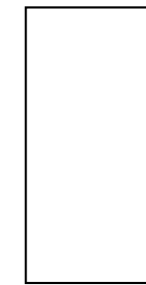

30x60 cm  
11,8x23,6"

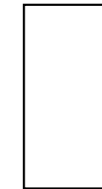

FINISHED

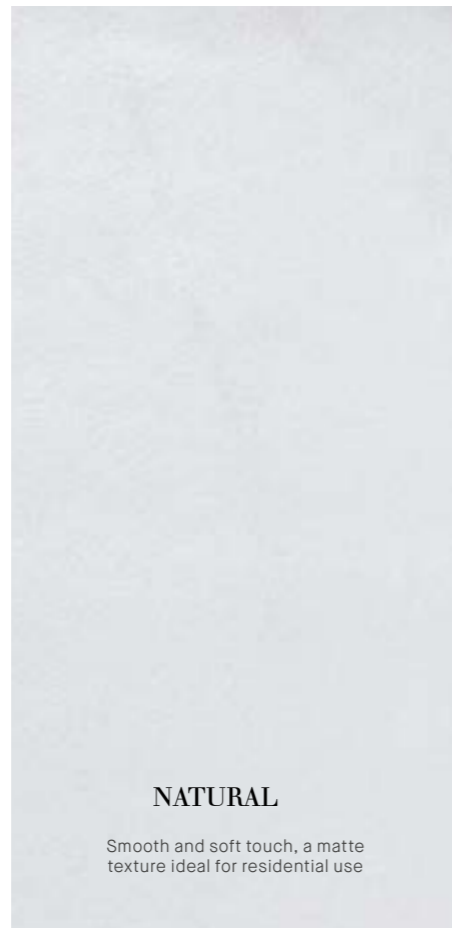
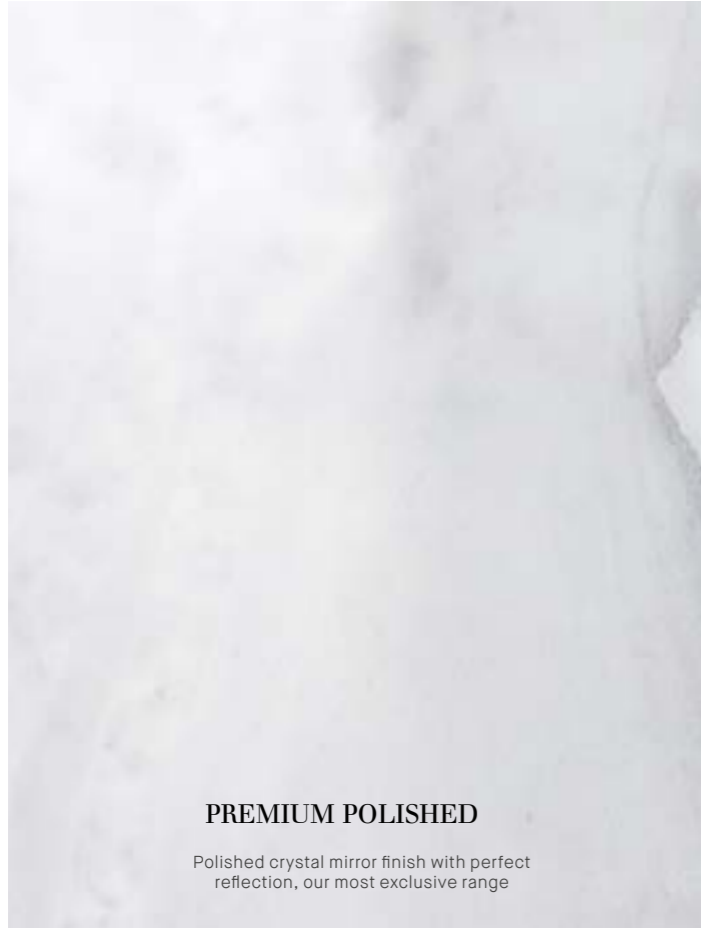

TESTS

Essay	Features	Result				
		PREMIUM POLISHED (P)	POLISHED (EP)	NATURAL (NAT)	RIVER-WASHED (RW)	FLAMED (FLAM)
DIN 51130	Critical angle (Inclined platform)	—	—	—	R9	R11
UNE-ENV 12633	Slip resistance (Pendulum test)	—	—	Class 1	Class 1	Class 3
BS 7976-2	Slip resistance (Pendulum test - PTV)	—	—	—	+36 Wet	+36 Wet
ANSI A137.1	Dynamic Coefficient of Friction (DCOF)	—	—	>0,42 Wet	>0,42 Wet	>0,42 Wet

TECHNICAL CHARACTERISTICS

	JOINT	FROST PROOF	VERSATILE	RECTIFIED	DIFERENT SHADES	V1 V2 V3 V4 SHADE VARIATION	VARIOUS GRAPHICS	CLEANING NON-ABRASIVE
PREMIUM POLISHED (P)	✓	✓	✓	✓	✓	✓	✓	✓
POLISHED (EP)	✓	✓	✓	✓	✓	✓	✓	✓
NATURAL (NAT)	✓	✓	✓	✓	✓	✓	✓	✓
RIVER-WASHED (RW)	✓	✓	✓	✓	✓	✓	✓	✓
FLAMED (FLAM)	✓	✓	✓	✓	✓	✓	✓	✓

APPLICATIONS

Area	Wall					Floor				
	P	EP	NAT	RW	FLAM	P	EP	NAT	RW	FLAM
Interior	yes	yes	yes	yes	yes	yes	yes	yes	yes	yes
Exterior	yes	yes	yes	yes	yes	yes	yes	yes	yes	yes
Traffic	yes	yes	yes	yes	yes	light	light	light	medium	high
Wet areas	yes	yes	yes	yes	yes	no	no	no	no	yes



**BREAKING THE BOUNDARIES OF EXCELLENCE**

4D TECH is the most innovative tile manufacturing system on the market, based on exclusive new technology aimed at guaranteeing quality second to none.

**THE NEW MUSEUM RANGE**

Thanks to the use of new 4D TECH technology, Museum has broken its own record for excellence, achieving a level of precision and versatility that no other tile range can equal.

---

**DIMENSIONS**

**Even more formats**

New more varied formats. With 4DTECH technology, there are no limits to the formats that can be produced and so there are no limits to the settings where our exclusive products can be used.

---

**DESIGN**

**Limitless creativity**

Collections developed with 4TECH and its improved technology break new ground in design, thanks to its new aesthetic and material-related potential for creating products that are simply unique.

---

**DEFINITION**

**Simply amazing detail**

Opening up new ground in precision and tile finishes. Thanks to our new production system, not only can we improve on real sources of inspiration but we can also reinvent nature through products like nothing you will have ever seen.

---







**DISTINCTION**

**Committed to innovation**

With the arrival of new 4DTECH technology, Museum has yet again demonstrated that it is a trailblazer in the introduction of technological innovations, guaranteeing consumers exclusive products that are a cut above all the rest.

[www.museumsurfaces4d.com](http://www.museumsurfaces4d.com)









Pág.						
	100x180 cm 29,7x59,4"	100x100 cm 29,7x59,4"	50x100 cm 29,7x59,4"	19,5x150 cm 29,7x59,4"	75,5x151 cm 29,7x59,4"	90x90 cm 35,4x35,4"

AGATHA	246					
BANSKY	294					
BARDIGLIO	62				EP RW	
BASATI	105				EP NAT	
CALACATTA 4D	16	P NAT				
CAPITAL	252					
CONCEPT	288					
DEEP 4D	20	P NAT				
ETERNAL 4D	26	P NAT				
FIDIAS	146					EP
FREEZE	152					EP
GIOIA	156					EP
GREVIN	208					
GREYSTONE	74				EP NAT	EP NAT
HETTANGIAN FLOOR	162					EP
KRITIOS	170					EP
LED	284					EP
LENS	212					
LUMINA	222					
LUXURY	280					
MACBA - MUVIM	256					
MADISON	176					EP
MARQ	226					
MARQUINA	83				EP NAT	EP NAT
MENHIR	230					
METROPOLITAN FLOOR	182					EP
NARA	110				EP NAT	
ONIX	118				EP	
OPALO, BACH, ONICE, ZAR	262					
ORIO	188					EP
PERSEPOLIS	268					
PETRA	274					
RUGBY 4D	32	P NAT		P NAT		
SANTANA	124				EP	
SHERWOOD OAK 4D	54				NAT	
SOLTO 4D	42	P NAT		P NAT		
STATE	192					EP
STATUARIO PLUS	92				EP NAT	EP NAT
STIAVA	196					EP
SUITE	128				EP	
SUNSHINE	202					EP
TORANO	138				EP NAT	EP NAT
TUCCI	234					
VOGUE	242					

## FINISH

EP — POLISHED  
P — PREMIUM POLISHED  
NAT — NATURAL  
RW — NATURAL RIVERWASHED  
F — FLAMED

					
45x90 cm 17,7x35,4"	60x120 cm 23,6x47,2"	19,5x120 cm 23,6x47,2"	60x60 cm 23,6x23,6"	30x60 cm 11,8x23,6"	44x44 cm 17,3x17,3"

						P				P	246	AGATHA	
										P	294	BANSKY	
						EP		F			62	BARDIGLIO	
											105	BASATI	
											16	CALACATTA 4D	
										P	252	CAPITAL	
										P	288	CONCEPT	
											20	DEEP 4D	
											26	ETERNAL 4D	
						EP				P	146	FIDIAS	
						EP					152	FREEZE	
						EP					156	GIOIA	
						EP					208	GREVIN	
						EP NAT					74	GREYSTONE	
						EP					162	HETTANGIAN FLOOR	
						EP					170	KRITIOS	
								RW		RW		284	LED
										P	212	LENS	
						P		EP			222	LUMINA	
										P	280	LUXURY	
										P	256	MACBA - MUVIM	
						EP					176	MADISON	
						EP					226	MARQ	
						EP NAT					83	MARQUINA	
						P					230	MENHIR	
						EP				EP NAT		182	METROPOLITAN FLOOR
						EP NAT					110	NARA	
						EP					118	ONIX	
										P		262	OPALO, BACH, ONICE, ZAR
										P	188	ORIO	
										P	268	PERSEPOLIS	
										P	274	PETRA	
											32	RUGBY 4D	
											124	SANTANA	
											54	SHERWOOD OAK 4D	
											42	SOLTO 4D	
											192	STATE	
											92	STATUARIO PLUS	
										EP NAT	196	STIAVA	
										EP	128	SUITE	
										EP	202	SUNSHINE	
										EP NAT	138	TORANO	
										P	234	TUCCI	
										P	242	VOGUE	



Calacatta 4D



Calacatta 4D — Extra white

**4**<sup>TECH</sup> 8 mm - 0,31"  
THICKNESS

Colors / Colores



Extra white

Finished / Acabados



premium polished



natural

Dimensions / Dimensiones

100 × 180 cm  
39,3 × 70,8"

100 × 100 cm  
39,3 × 39,3"

20 patterns

20 patterns

Shade variation: V3

Thickness: 8 mm / 0,31"

References / Referencias

Price code

24203 CALACATTA EXTRA WHITE/100X180/P	M76
23211 CALACATTA EXTRA WHITE/100X180/NAT/R	M75
24206 CALACATTA EXTRA WHITE/100X100/P	M76
23977 CALACATTA EXTRA WHITE/100X100/NAT/R	M75



Deep 4D



8 mm - 0,31"  
THICKNESS

Deep 4D





Deep — Black

**4**  
TECH 8 mm - 0,31"  
THICKNESS

Colors / Colores



Black

Finished / Acabados

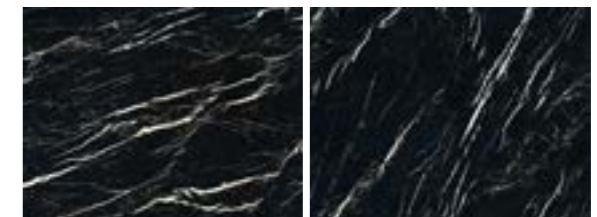

premium polished

natural

Dimensions / Dimensiones



12 patterns  
Shade variation: V3  
Thickness: 8 mm / 0,31"

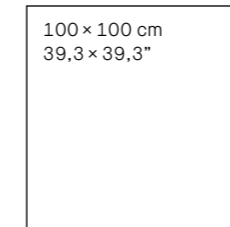

12 patterns

References / Referencias

	Price code
24201 DEEP BLACK/100X180/P	M76
23973 DEEP BLACK/100X180/NAT/R	M75
24205 DEEP BLACK/100X100/P	M76
23975 DEEP BLACK/100X100/NAT/R	M75



Eternal 4D







Eternal — White

**4**  
TECH 8 mm - 0,31"  
THICKNESS

Colors / Colores



white

Finished / Acabados



premium polished



natural

Dimensions / Dimensiones

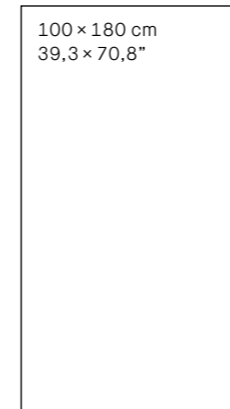

15 patterns  
Shade variation: V3  
Thickness: 8 mm / 0,31"

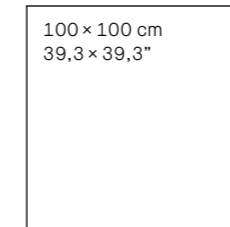

15 patterns

References / Referencias

Price code

24202 ETERNAL WHITE/100X180/P	M76
23970 ETERNAL WHITE/100X180/NAT/R	M75
24204 ETERNAL WHITE/100X100/P	M76
23976 ETERNAL WHITE/100X100/NAT/R	M75



Rugby 4D



8 mm - 0,31"  
THICKNESS

Rugby 4D







8 mm - 0,31"  
THICKNESS

Rugby 4D

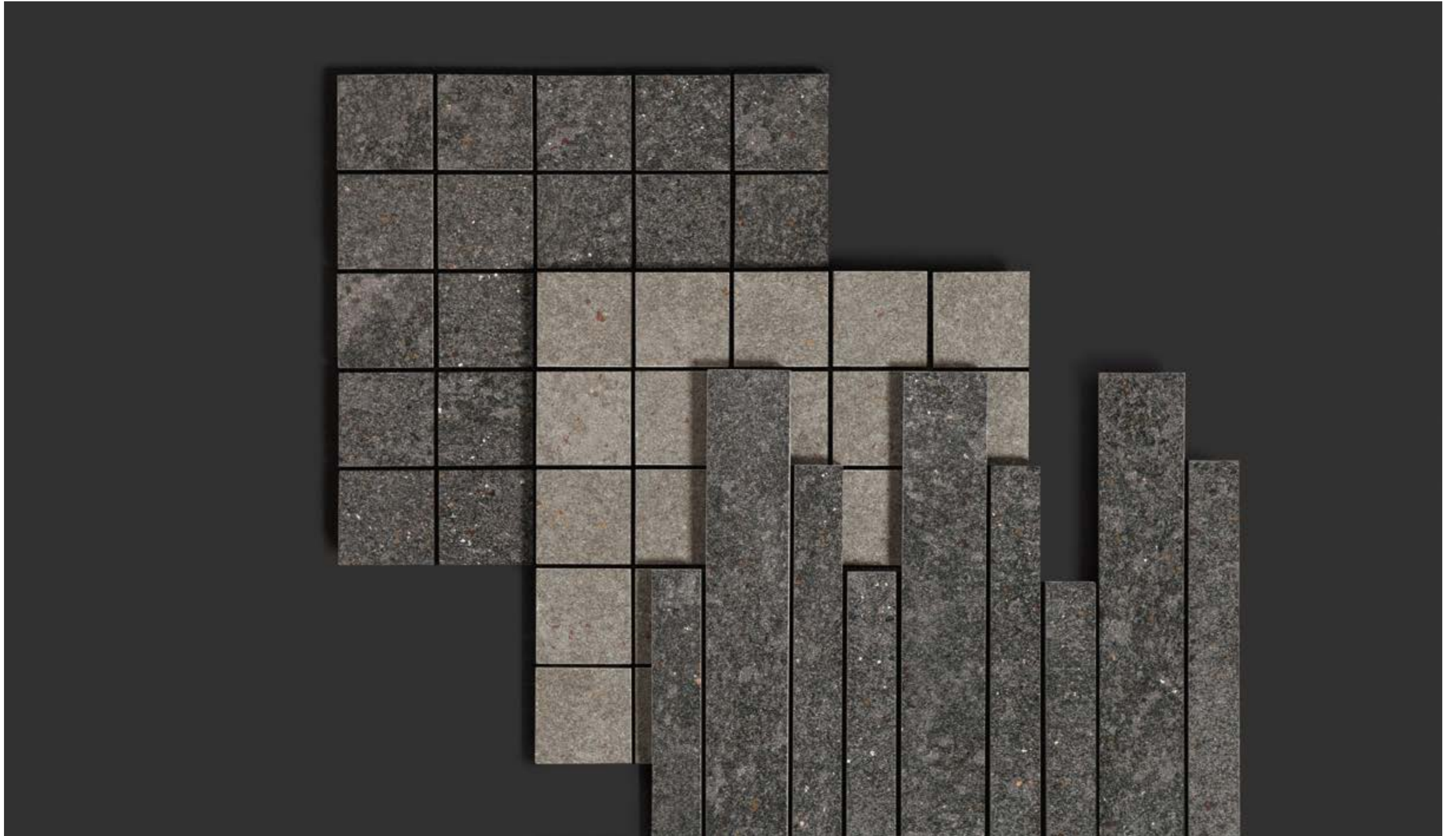



Rugby — Black

**4**  
TECH 8 mm - 0,31"  
THICKNESS

Colors / Colores



black Grey

Finished / Acabados



premium polished natural

Dimensions / Dimensiones

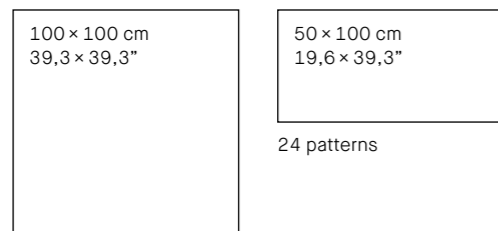

12 patterns  
Shade variation: V2  
Thickness: 8 mm / 0,31"

References / Referencias

References / Referencias	Price code
23432 RUGBY BLACK/100X100/P	M70
23446 RUGBY BLACK/100X100/NAT/R	M69
23434 RUGBY BLACK/50X100/NAT/R	M69
23431 RUGBY GREY/100X100/P	M70
23445 RUGBY GREY/100X100/NAT/R	M69
23433 RUGBY GREY/50X100/NAT/R	M69

Rugby — Grey

**4**  
TECH 8 mm - 0,31"  
THICKNESS

Decorados / Decors

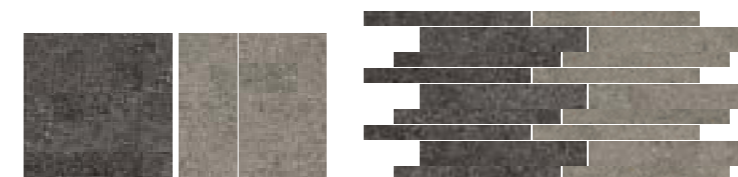

black Grey black Grey

Dimensions / Dimensiones

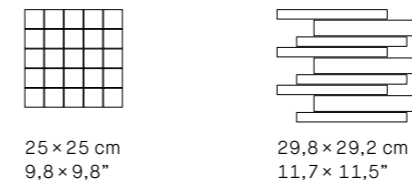

25 x 25 cm  
9,8 x 9,8"

29,8 x 29,2 cm  
11,7 x 11,5"

References / Referencias

References / Referencias	Price code
23550 D. RUGBY BLACK MOSAIC/25X25/P	U44
23551 D. RUGBY BLACK MOSAIC/25X25/NAT	U39
23554 D. RUGBY BLACK BRICK/29,8X29,2/P	U51
23555 D. RUGBY BLACK BRICK/29,8X29,2/NAT	U50
23549 D. RUGBY GREY MOSAIC/25X25/P	U44
23552 D. RUGBY GREY MOSAIC/25X25/NAT	U39
23553 D. RUGBY GREY BRICK/29,8X29,2/P	U51
23556 D. RUGBY GREY BRICK/29,8X29,2/NAT	U50



Solto 4D



8 mm - 0,31"  
THICKNESS

Solto 4D







8 mm - 0,31"  
THICKNESS

Solto 4D





8 mm - 0,31"  
THICKNESS

Solto 4D





8 mm - 0,31"  
THICKNESS

Solto 4D

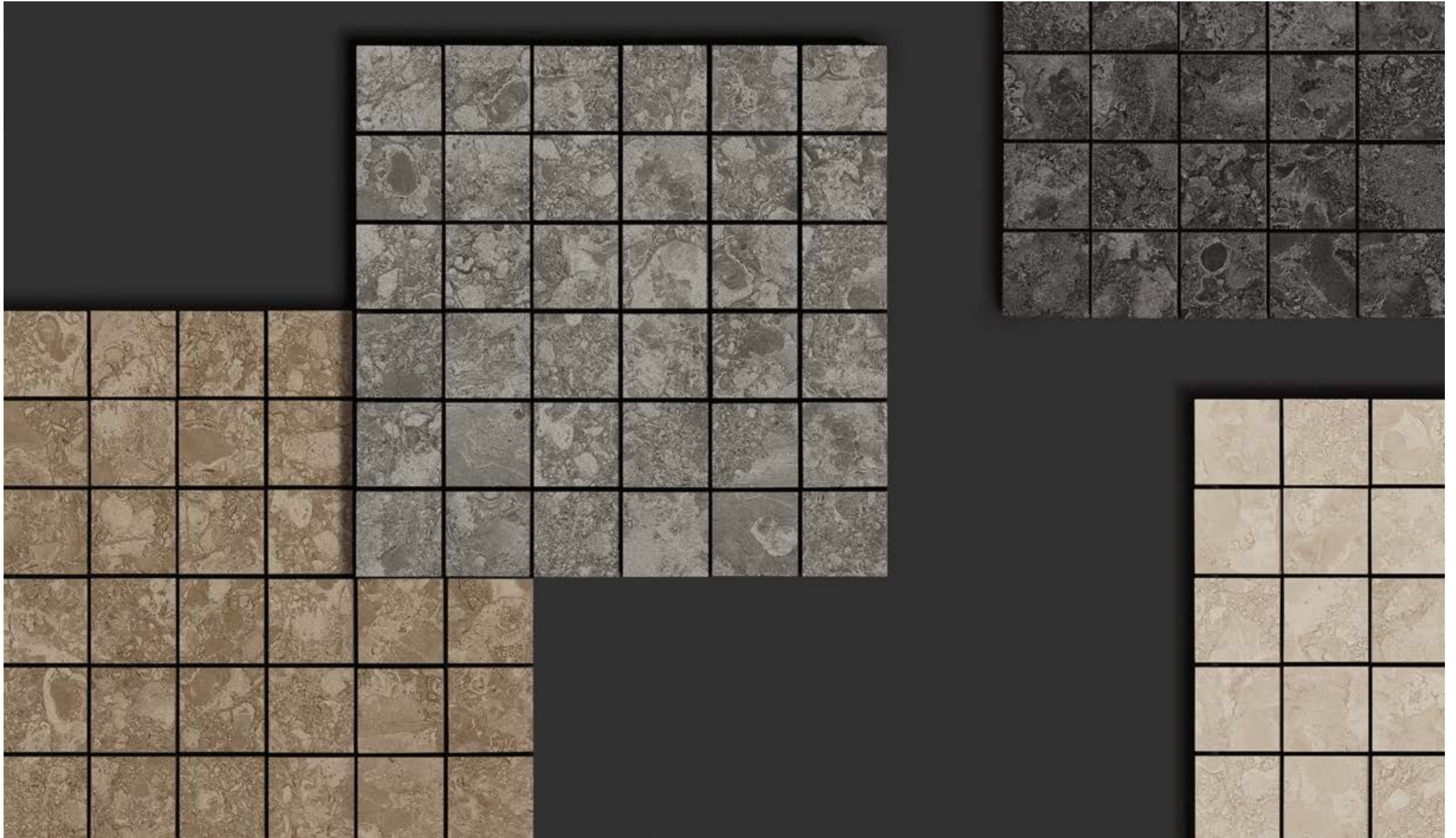

D. SOLTO TAUPE MOSAIC/25X25/RW — D. SOLTO SAND MOSAIC/25X25/RW  
D. SOLTO BLACK MOSAIC/25X25/RW — D. SOLTO GREY MOSAIC/25X25/RW



Solto 4D

**4**  
TECH 8 mm - 0,31"  
THICKNESS

Colors / Colores



Taupe Sand Black Grey

Finished / Acabados

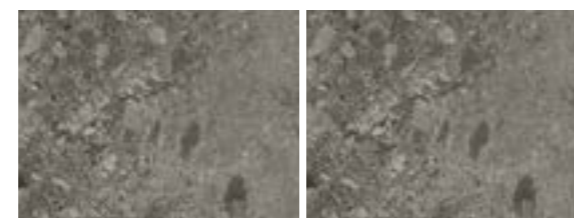

premium polished river-washed

Dimensions / Dimensiones

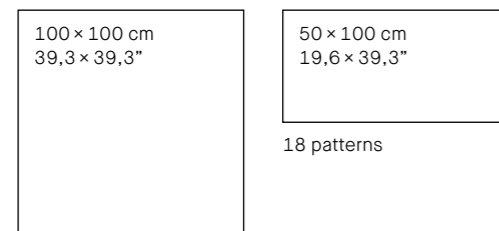

9 patterns  
Shade variation: V2  
Thickness: 8 mm / 0,31"

References / Referencias

References / Referencias	Price code
22307 SOLTO TAUPE/100X100/P	M70
22209 SOLTO TAUPE/100X100/RW/R	M69
22214 SOLTO TAUPE/50X100/RW/R	M69
22306 SOLTO SAND/100X100/P	M70
22208 SOLTO SAND/100X100/RW/R	M69
22213 SOLTO SAND/50X100/RW/R	M69
22309 SOLTO GREY/100X100/P	M70
22210 SOLTO GREY/100X100/RW/R	M69
22215 SOLTO GREY/50X100/RW/R	M69
22308 SOLTO BLACK/100X100/P	M70
22211 SOLTO BLACK/100X100/RW/R	M69
22212 SOLTO BLACK/50X100/RW/R	M69

Solto 4D

**4**  
TECH 8 mm - 0,31"  
THICKNESS

Decorados / Decors

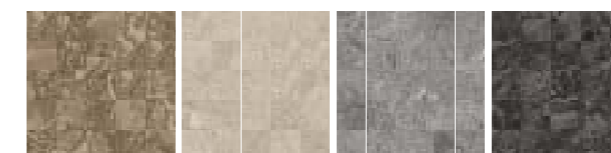

Taupe Sand Black Grey

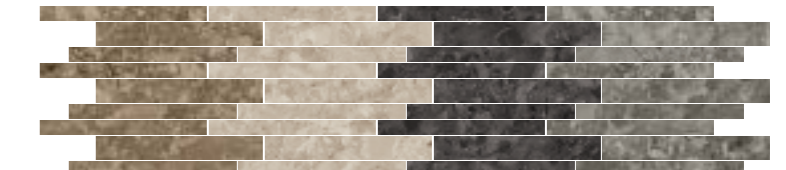

Taupe Sand Black Grey

Dimensions / Dimensiones

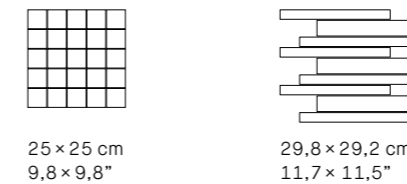

25 x 25 cm  
9,8 x 9,8"

29,8 x 29,2 cm  
11,7 x 11,5"

References / Referencias

References / Referencias	Price code
22745 D. SOLTO TAUPE MOSAIC/25X25/P	U44
22749 D. SOLTO TAUPE MOSAIC/25X25/RW	U39
22753 D. SOLTO TAUPE BRICK/29,8X29,2/P	U51
22757 D. SOLTO TAUPE BRICK/29,8X29,2/RW	U50
22743 D. SOLTO SAND MOSAIC/25X25/P	U44
22748 D. SOLTO SAND MOSAIC/25X25/RW	U39
22752 D. SOLTO SAND BRICK/29,8X29,2/P	U51
22756 D. SOLTO SAND BRICK/29,8X29,2/RW	U50
22747 D. SOLTO BLACK MOSAIC/25X25/P	U44
22751 D. SOLTO BLACK MOSAIC/25X25/RW	U39
22755 D. SOLTO BLACK BRICK/29,8X29,2/P	U44
22759 D. SOLTO BLACK BRICK/29,8X29,2/RW	U50
22746 D. SOLTO GREY MOSAIC/25X25/P	U44
22750 D. SOLTO GREY MOSAIC/25X25/RW	U39
22754 D. SOLTO GREY BRICK/29,8X29,2/P	U44
22758 D. SOLTO GREY BRICK/29,8X29,2/RW	U39



Sherwood oak 4D



8 mm - 0,31"  
THICKNESS

Sherwood oak 4D





Solto 4D



## Sherwood Oak

**4**  
TECH 8 mm - 0,31"  
THICKNESS

### Colors / Colores

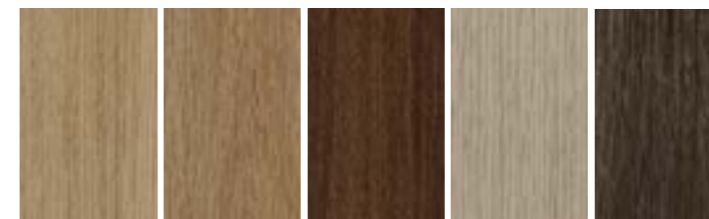

Honey Cognac Porto Kalua Ebony

### Finished / Acabados



natural

### Dimensions / Dimensiones

19,5 × 150 cm - 7,6 × 59"

50 patterns

Shade variation: V3

Thickness: 8 mm / 0,31"

### References / Referencias

Reference	Product Name	Price code
23629	SHERWOOD HONEY/19,5X150/NAT/R	M71
23609	SHERWOOD COGNAC/ 19,5X150/NAT/R	M71
23454	SHERWOOD PORTO/19,5X150/NAT/R	M71
23630	SHERWOOD KALUA/19,5X150/NAT/R	M71
23611	SHERWOOD EBONY/19,5X150/NAT/R	M71





# Bardiglio











## Bardiglio — Pearl

### Colors / Colores

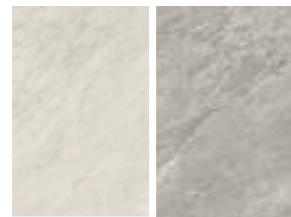

Pearl Grey

### Finished / Acabados



polished river-washed Flam

### Dimensions / Dimensiones

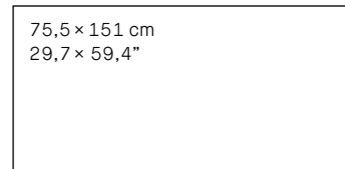

75,5 × 151 cm  
29,7 × 59,4"

40 patterns

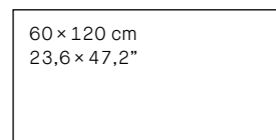

60 × 120 cm  
23,6 × 47,2"

40 patterns

Shade variation: V2

### References / Referencias

References / Referencias	Price code
21067 BARDIGLIO PEARL/75,5x151/EP	M58
21073 BARDIGLIO PEARL/75,5x151/RW/R	M59
22060 BARDIGLIO PEARL/60x120/EP	M40
22115 BARDIGLIO PEARL/60x120/FLAM/R	M66
22112 BARDIGLIO PEARL/60x120/RW/R	M66
21066 BARDIGLIO GREY/75,5x151/EP	M58
21072 BARDIGLIO GREY/75,5x151/RW/R	M59
22059 BARDIGLIO GREY/60x120/EP	M40
22114 BARDIGLIO GREY/60x120/FLAM/R	M66
22113 BARDIGLIO GREY/60x120/RW/R	M66

## Bardiglio — Grey

### Decorados / Decors

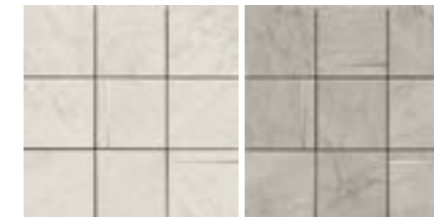

Pearl Grey

### Dimensions / Dimensiones

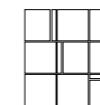

30 × 30 cm  
11,8 × 11,8"

mixed finishes  
polished | river-washed

### References / Referencias

References / Referencias	Price code
22250 D. BARDIGLIO PEARL MOSAIC/30X30	U58
22249 D. BARDIGLIO GREY MOSAIC/30X30	U58

22302 L.ALUMINUM/120/MATT U44 (0,5x120 cm - 0,19x47,2 ")

22314 L.ALUMINUM/120/SHINE U44 (0,5x120 cm - 0,19x47,2 ")



Greystone





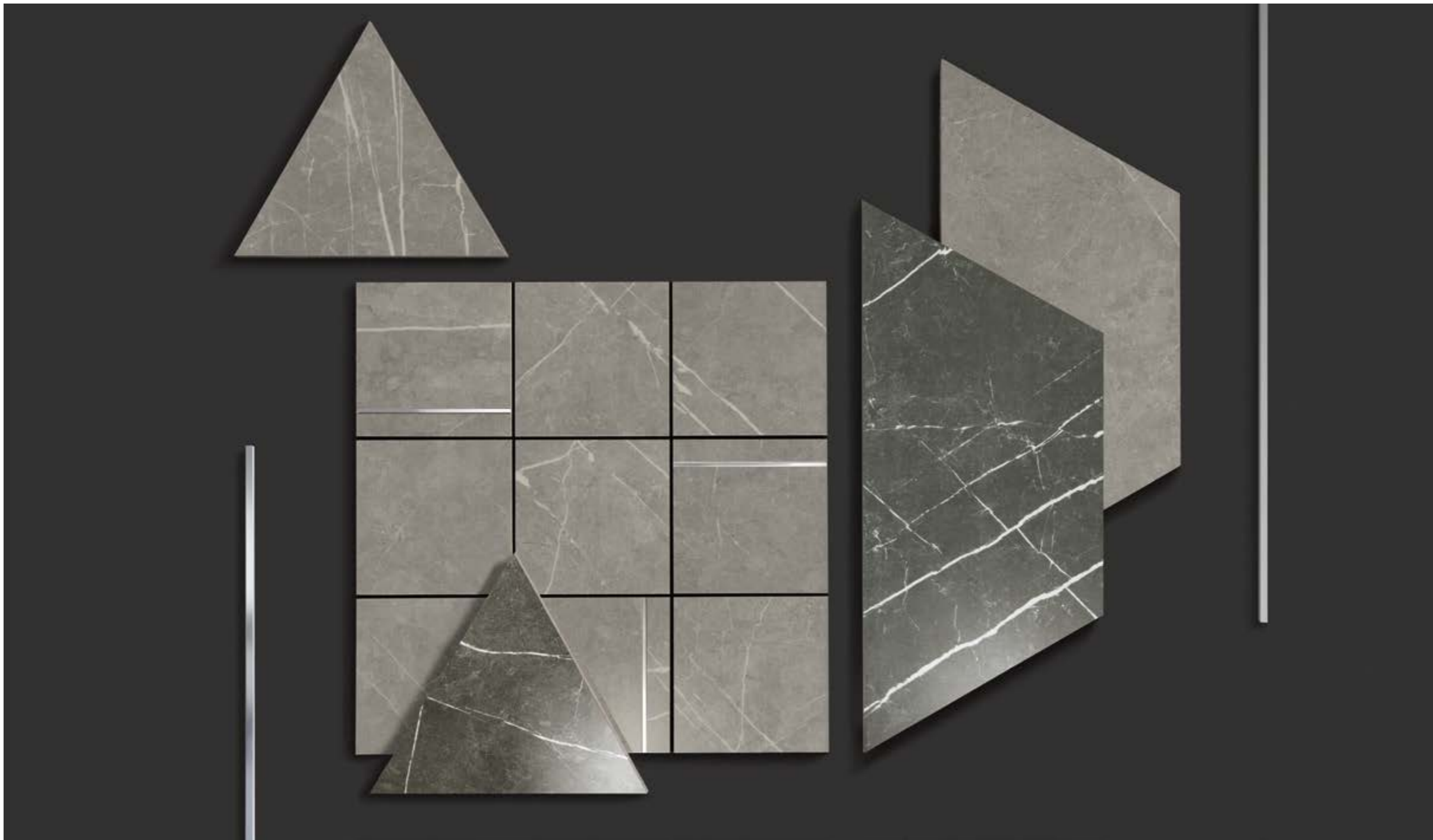

D. GREYSTONE ARGEN MOSAIC/30X30/EP — TRAP. GREYSTONE ARGENT/34,5X15/NAT  
TRAP. GREYSTONE SMOKE/34,5X15/NAT — TRI. GREYSTONE ARGENT/17,2X15/NAT  
TRI. GREYSTONE SMOKE/17,2X15/NAT



## Greystone— Argent

## Greystone— Smoke

### Colors / Colores

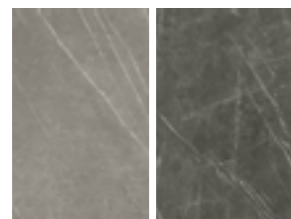

Argent

Smoke

### Finished / Acabados

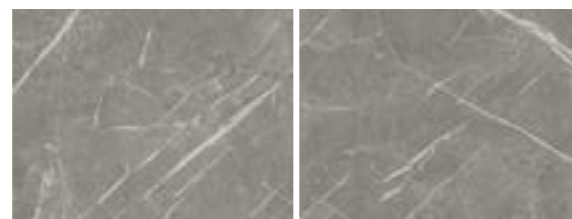

polished

natural

### Decorados / Decors

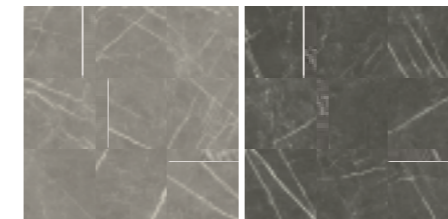

Argent

Smoke



Argent

Smoke



Argent

Smoke



greystone—marquina  
statuario plus

### Dimensions / Dimensiones

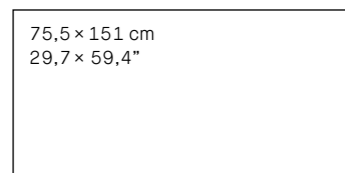

12 patterns

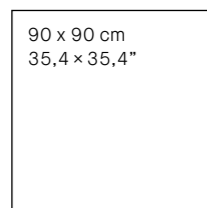

12 patterns

Shade variation: V2

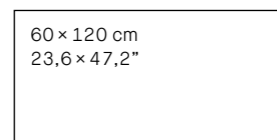

15 patterns

### References / Referencias

References / Referencias	Price code
23447 GREYSTONE ARGENT/75,5x151/EP	M58
23475 GREYSTONE ARGENT/75,5x151/NAT/R	M59
23459 GREYSTONE ARGENT/60x120/EP	M40
23469 GREYSTONE ARGENT/60x120/NAT/R	M66
23295 GREYSTONE ARGENT/90x90/EP	M2
23478 GREYSTONE ARGENT/90x90/NAT/R	M68
23448 GREYSTONE SMOKE/75,5x151/EP	M58
23474 GREYSTONE SMOKE/75,5x151/NAT/R	M59
23460 GREYSTONE SMOKE/60x120/EP	M40
23470 GREYSTONE SMOKE/60x120/NAT/R	M66
23296 GREYSTONE SMOKE/90x90/EP	M2
23477 GREYSTONE SMOKE/90x90/NAT/R	M68

### Dimensions / Dimensiones

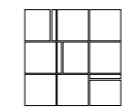

30 x 30 cm  
11,8 x 11,8"



34,5 x 15 cm  
13,6 x 5,9"

mixed  
finishes  
polished | natural



16 x 25 cm  
6,3 x 9,8"



17,2 x 15 cm  
6,7 x 5,9"

greystone  
marquina  
statuario plus

### References / Referencias

References / Referencias	Price code
23539 D. GREYSTONE ARGEN MOSAIC/30X30/EP	U58
23540 D. GREYSTONE SMOKE MOSAIC/30X30/EP	U58
23558 TRAP. GREYSTONE ARGENT/34,5x15/EP	U28
23683 TRAP. GREYSTONE ARGENT/34,5x15/NAT	U28
23562 TRAP. GREYSTONE SMOKE/34,5x15/EP	U28
23684 TRAP. GREYSTONE SMOKE/34,5x15/NAT	U28
23557 TRI. GREYSTONE ARGENT/17,2x15/EP	U13
23687 TRI. GREYSTONE ARGENT/17,2x15/NAT	U13
23559 TRI. GREYSTONE SMOKE/17,2x15/EP	U13
23688 TRI. GREYSTONE SMOKE/17,2x15/NAT	U13
23537 D. STONE MIX ARR./16X25/EP	U49

22302 L.ALUMINUM/120/MATT U44 (0,5x120 cm - 0,19x47,2 ")



22314 L.ALUMINUM/120/SHINE U44 (0,5x120 cm - 0,19x47,2 ")





Marquina







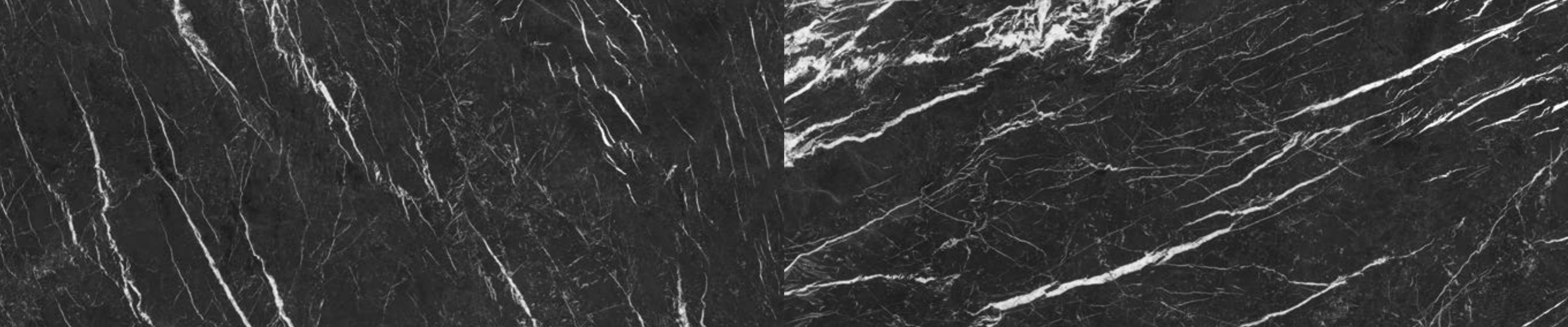

Marquina — Black

Colors / Colores

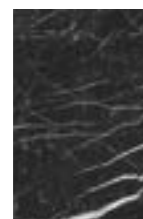

Black

Finished / Acabados

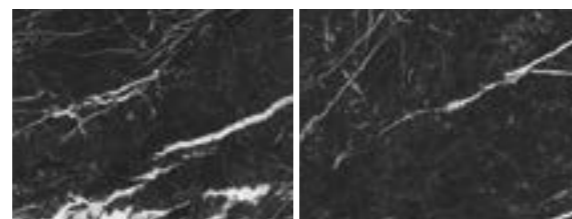

polished

natural

Marquina — Black

Decorados / Decors



Black

Black

Black

greystone—marquina  
statuario plus

Dimensions / Dimensiones

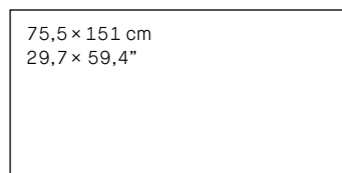

75,5 × 151 cm  
29,7 × 59,4"

12 patterns

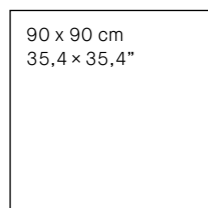

90 × 90 cm  
35,4 × 35,4"

12 patterns

Shade variation: V2

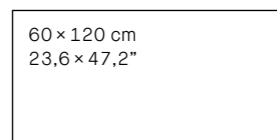

60 × 120 cm  
23,6 × 47,2"

15 patterns

References / Referencias

References / Referencias	Price code
23453 MARQUINA BLACK/75,5x151/EP	M74
23473 MARQUINA BLACK/75,5x151/NAT/R	M59
23461 MARQUINA BLACK/60x120/EP	M73
23471 MARQUINA BLACK/60x120/NAT/R	M66
23297 MARQUINA BLACK/90x90/EP	M72
23479 MARQUINA BLACK/90x90/NAT/R	M68

Dimensions / Dimensiones

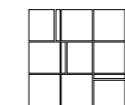

30 × 30 cm  
11,8 × 11,8"



34,5 × 15 cm  
13,6 × 5,9"



16 × 25 cm  
6,3 × 9,8"



17,2 × 15 cm  
6,7 × 5,9"

References / Referencias

References / Referencias	Price code
23542 D. MARQUINA BLACK MOSAIC/30X30/EP	U58
23560 TRI. MARQUINA BLACK/17,2x15/EP	U13
23689 TRI. MARQUINA BLACK/17,2x15/NAT	U13
23563 TRAP. MARQUINA BLACK/34,5x15/EP	U28
23686 TRAP. MARQUINA BLACK/34,5x15/NAT	U28
23537 D. STONE MIX ARR./16X25/EP	U49

22302 L.ALUMINUM/120/MATT U44 (0,5x120 cm - 0,19x47,2 ")



22314 L.ALUMINUM/120/SHINE U44 (0,5x120 cm - 0,19x47,2 ")





# Statuario Plus







D. STATUARIO PLUS MOSAIC/30X30/EP — TRI. STATUARIO PLUS/17,2x15/NAT  
TRAP. STATUARIO PLUS/34,5x15/NAT — D. STONE MIX ARR./16X25/EP



## Statuario Plus

### Colors / Colores



### Finished / Acabados



polished

natural

## Statuario Plus

### Decorados / Decors



greystone—marquina  
statuario plus

### Dimensions / Dimensiones

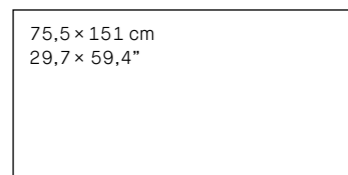

75,5 × 151 cm  
29,7 × 59,4"

15 patterns

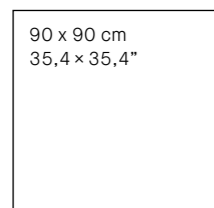

90 × 90 cm  
35,4 × 35,4"

12 patterns

Shade variation: V2

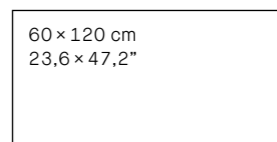

60 × 120 cm  
23,6 × 47,2"

16 patterns

### References / Referencias

References / Referencias	Price code
23463 STATUARIO PLUS/75,5x151/EP	M58
23476 STATUARIO PLUS/75,5x151/NAT/R	M59
23462 STATUARIO PLUS/60x120/EP	M40
23472 STATUARIO PLUS/60x120/NAT/R	M66
23298 STATUARIO PLUS/90x90/EP	M2
23480 STATUARIO PLUS/90x90/NAT/R	M68

### Dimensions / Dimensiones

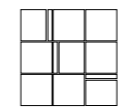

30 × 30 cm  
11,8 × 11,8"

mixed  
finishes  
polished | natural

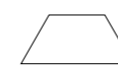

34,5 × 15 cm  
13,6 × 5,9"



16 × 25 cm  
6,3 × 9,8"







17,2 × 15 cm  
6,7 × 5,9"

greystone  
marquina  
statuario plus

### References / Referencias

References / Referencias	Price code
23541 D. STATUARIO PLUS MOSAIC/30X30/EP	U58
23561 TRI. STATUARIO PLUS/17,2x15/EP	U13
23690 TRI. STATUARIO PLUS/17,2x15/NAT	U13
23564 TRAP. STATUARIO PLUS/34,5x15/EP	U28
23685 TRAP. STATUARIO PLUS/34,5x15/NAT	U28
23537 D. STONE MIX ARR./16X25/EP	U49

22302 L.ALUMINUM/120/MATT U44 (0,5x120 cm - 0,19x47,2 ")    

22314 L.ALUMINUM/120/SHINE U44 (0,5x120 cm - 0,19x47,2 ")    



TRAP. GREYSTONE ARGENT/34,5X15/NAT — TRAP. GREYSTONE SMOKE/34,5X15/NAT  
TRAP. MARQUINA BLACK/34,5X15/NAT — TRAP. STATUARIO PLUS/34,5X15/EP

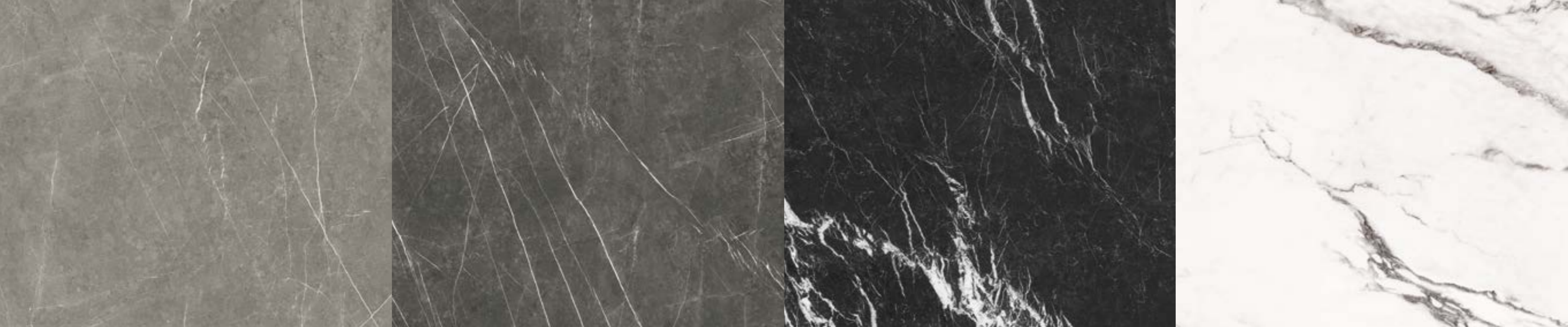

Greystone — Argent

Greystone — Smoke

Marquina — Black

Statuario plus

Colors / Colores

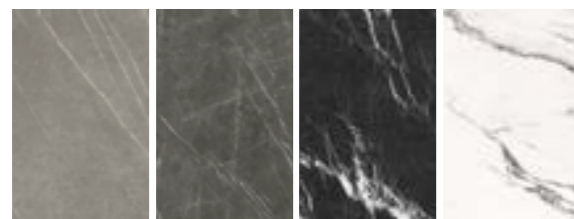

Argent Smoke Black Statuario plus

Finished / Acabados

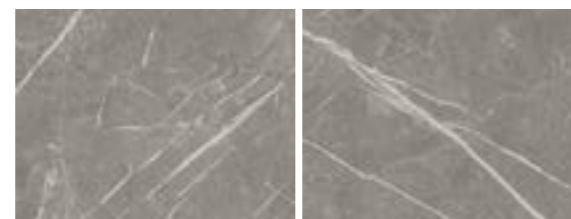

polished natural

Dimensions / Dimensiones

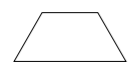

34,5 x 15 cm  
13,6 x 5,9"



17,2 x 15 cm  
6,7 x 5,9"

References / Referencias

Price code

23558	TRAP. GREYSTONE ARGENT/34,5x15/EP	U28
23683	TRAP. GREYSTONE ARGENT/34,5x15/NAT	U28
23562	TRAP. GREYSTONE SMOKE/34,5x15/EP	U28
23684	TRAP. GREYSTONE SMOKE/34,5x15/NAT	U28
23563	TRAP. MARQUINA BLACK/34,5x15/EP	U28
23686	TRAP. MARQUINA BLACK/34,5x15/NAT	U28
23564	TRAP. STATUARIO PLUS/34,5x15/EP	U28
23685	TRAP. STATUARIO PLUS/34,5x15/EP	U28
23557	TRI. GREYSTONE ARGENT/17,2x15/EP	U13
23687	TRI. GREYSTONE ARGENT/17,2x15/NAT	U13
23559	TRI. GREYSTONE SMOKE/17,2x15/EP	U13
23688	TRI. GREYSTONE SMOKE/17,2x15/NAT	U13
23560	TRI. MARQUINA BLACK/17,2x15/EP	U13
23689	TRI. MARQUINA BLACK/17,2x15/NAT	U13
23561	TRI. STATUARIO PLUS/17,2x15/EP	U13
23690	TRI. STATUARIO PLUS/17,2x15/EP	U13

installation patterns. examples of possible combinations

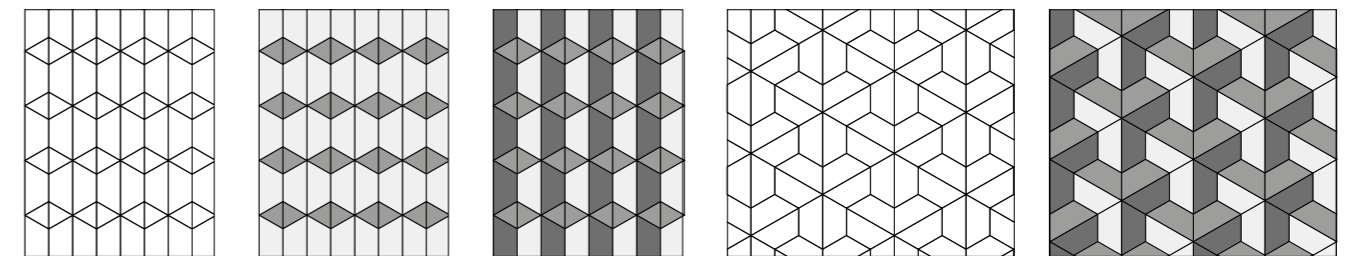

Pieces 1 m<sup>2</sup>  
21 TRI. \_ 21 TRAP.

Pieces 1 m<sup>2</sup>  
30 TRAP.

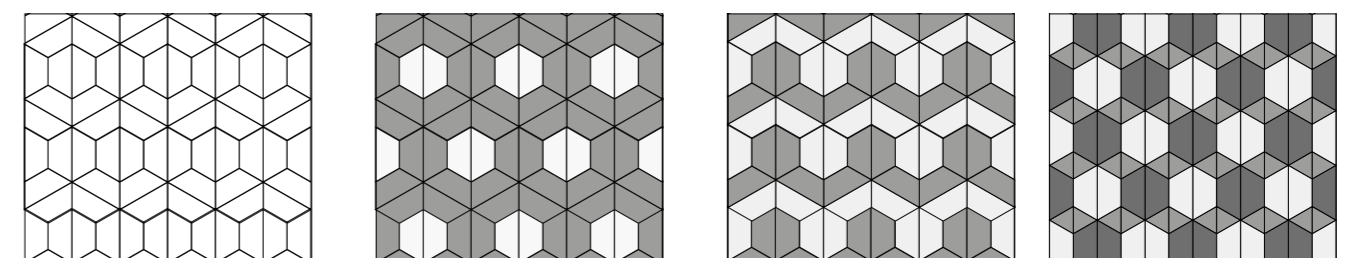

Pieces 1 m<sup>2</sup>  
30 TRAP.

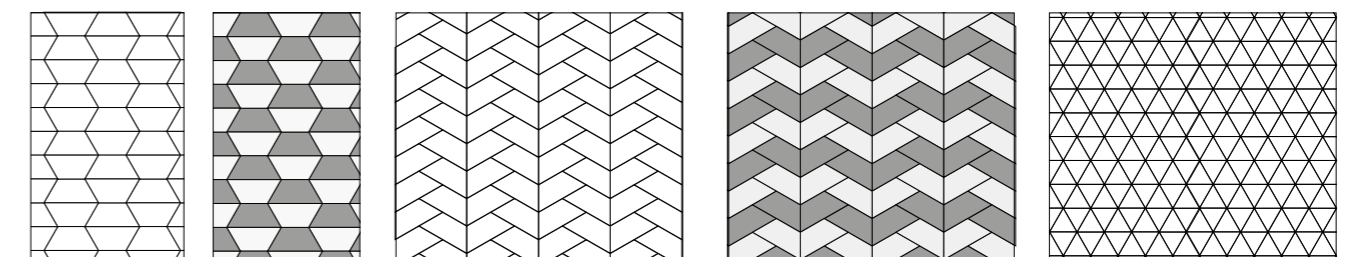

Pieces 1 m<sup>2</sup>  
28 TRAP.

Pieces 1 m<sup>2</sup>  
32 TRAP.

Pieces 1 m<sup>2</sup>  
84 TRI..



Basati





## Basati — Bianco

Colors / Colores



Bianco

Finished / Acabados

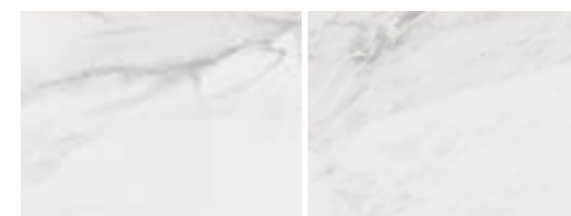

polished

natural

Decorados / Decors

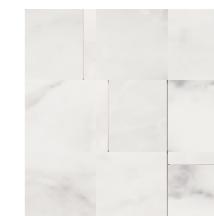

Bianco

Dimensions / Dimensiones

75,5 × 151 cm  
29,7 × 59,4"

40 patterns

Shade variation: V2

References / Referencias

21068 BASATI BIANCO/75,5x151/EP  
21071 BASATI BIANCO/75,5x151/NAT/R  
22251 D. BASATI BIANCO MOSAIC/30X30

Price code

M58  
M59  
U58





Nara





## Nara — White

### Colors / Colores

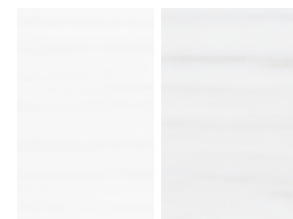

White

Pearl

### Finished / Acabados

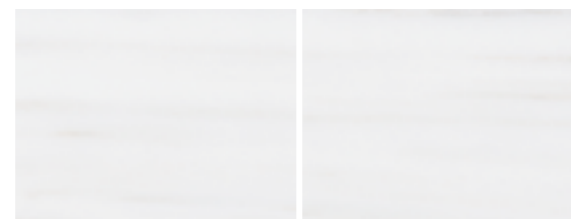

polished

natural

### Dimensions / Dimensiones

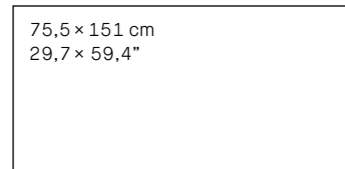

19 patterns

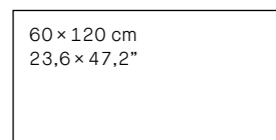

19 patterns

Shade variation: V2

### References / Referencias

References / Referencias	Price code
22134 NARA WHITE/75,5x151/EP	M58
22138 NARA WHITE/75,5x151/NAT/R	M59
22106 NARA WHITE/60x120/EP	M40
22108 NARA WHITE/60x120/NAT/R	M66
22135 NARA PEARL/75,5x151/EP	M58
22139 NARA PEARL/75,5x151/NAT/R	M59
22107 NARA PEARL/60x120/EP	M40
22109 NARA PEARL/60x120/NAT/R	M66

## Nara — Pearl

### Decorados / Decors

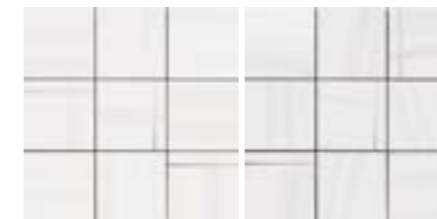

White

Pearl

### Dimensions / Dimensiones

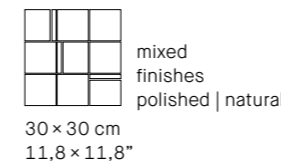

30 x 30 cm  
11,8 x 11,8"

mixed finishes  
polished | natural

### References / Referencias

References / Referencias	Price code
22248 D. NARA WHITE MOSAIC/30X30	U58
22247 D. NARA PEARL MOSAIC/30X30	U58

22302 L.ALUMINUM/120/MATT U44 (0,5x120 cm - 0,19x47,2 ")



22314 L.ALUMINUM/120/SHINE U44 (0,5x120 cm - 0,19x47,2 ")





Onix





## Onix — Pearl

### Colors / Colores



pearl

### Finished / Acabados



polished

### Dimensions / Dimensiones

75,5 × 151 cm  
29,7 × 59,4"

18 patterns

60 × 120 cm  
23,6 × 47,2"

18 patterns

Shade variation: V2

### References / Referencias

21069 ONIX PEARL/75,5x151/EP  
22110 ONIX PEARL/60x120/EP

### Price code

M58  
M40

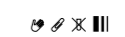



Santana





### Santana — White

#### Colors / Colores



White

#### Finished / Acabados



polished

#### Dimensions / Dimensiones

75,5 × 151 cm  
29,7 × 59,4"

14 patterns

60 × 120 cm  
23,6 × 47,2"

15 patterns

Shade variation: V2

#### References / Referencias

#### Price code

22143 SANTANA WHITE/75,5x151/EP  
22111 SANTANA WHITE/60x120/EP

M58  
M40





# Suite





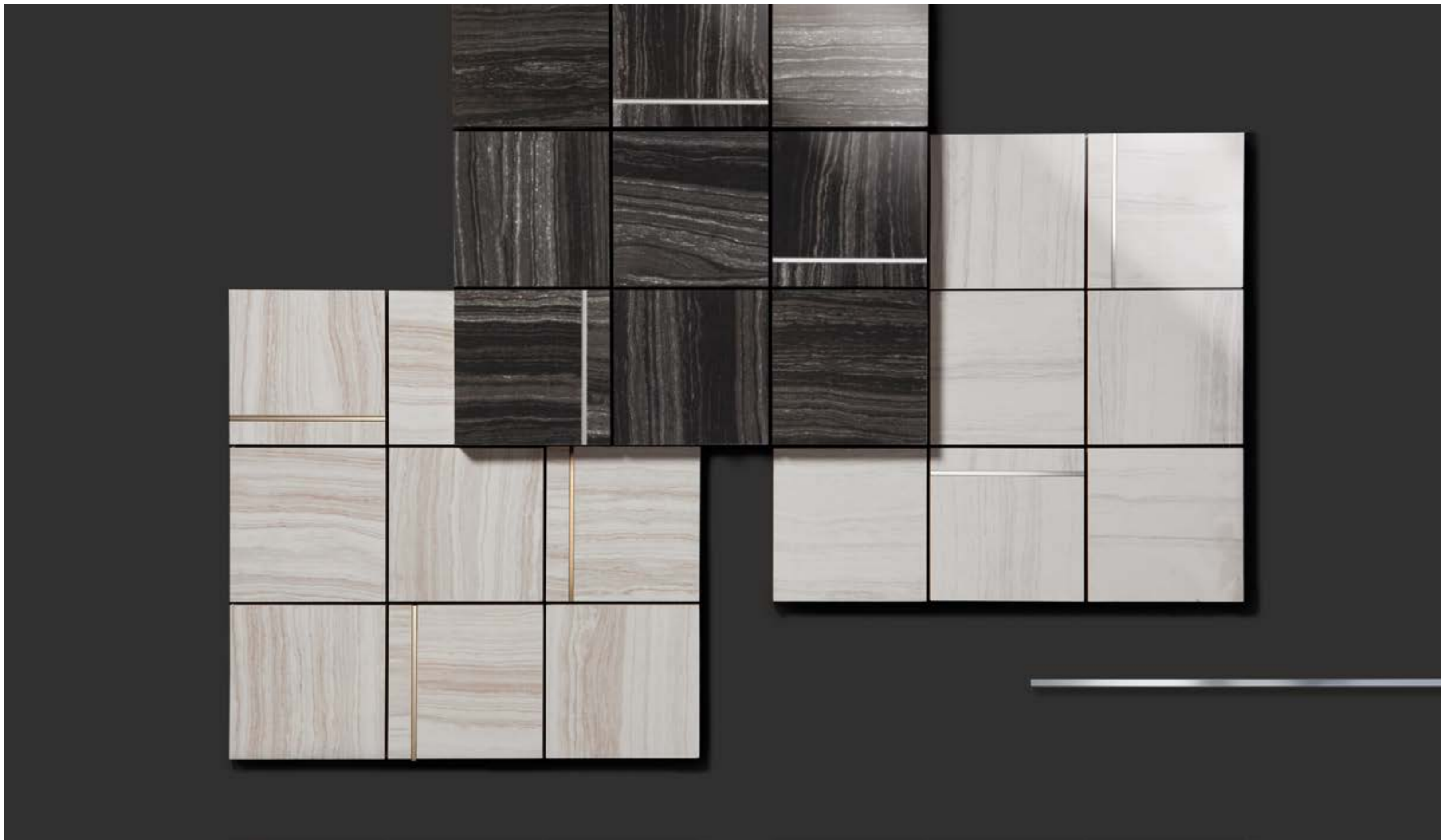

D. SUITE PEARL MOSAIC/30X30 — D. SUITE BEIGE MOSAIC/30X30  
D. SUITE BLACK MOSAIC/30X30



Suite

Colors / Colores

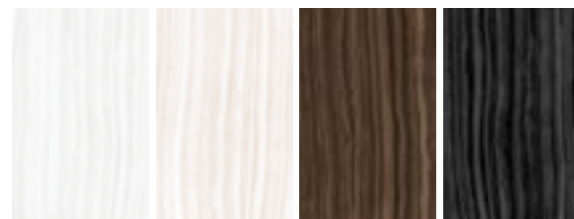

Pearl Beige Brown Black

Finished / Acabados



polished

Dimensions / Dimensiones

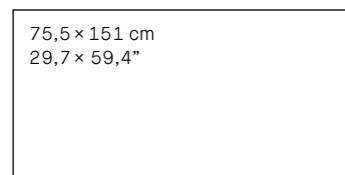

75,5 x 151 cm  
29,7 x 59,4"

12 patterns

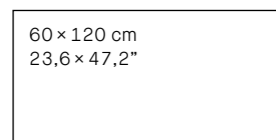

60 x 120 cm  
23,6 x 47,2"

12 patterns

Shade variation: V2

References / Referencias

22126 SUITE PEARL/75,5x151/EP	M58
22102 SUITE PEARL/60x120/EP	M40
22127 SUITE BEIGE/75,5x151/EP	M58
22103 SUITE BEIGE/60x120/EP	M40
22128 SUITE BROWN/75,5x151/EP	M58
22101 SUITE BROWN/60x120/EP	M40
22129 SUITE BLACK/75,5x151/EP	M58
22100 SUITE BLACK/60x120/EP	M40

Price code

Suite

Decorados / Decors



Pearl Beige Brown Black Pearl-black Beige-brown

Dimensions / Dimensiones

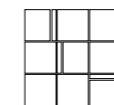

30 x 30 cm  
11,8 x 11,8"



16 x 25 cm  
6,3 x 9,8"

References / Referencias

22742 D. SUITE PEARL MOSAIC/30X30	U58
22740 D. SUITE BEIGE MOSAIC/30X30	U58
22741 D. SUITE BROWN MOSAIC/30X30	U58
22739 D. SUITE BLACK MOSAIC/30X30	U58
22775 D. SUITE PEARL MIX ARR./16X25	U49
22774 D. SUITE BEIGE MIX ARR./16X25	U49

Price code



Torano









## Torano — Bianco

### Colors / Colores

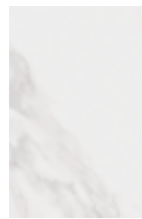

Bianco

### Finished / Acabados



polished

natural

### Decorados / Decors



Bianco

### Dimensions / Dimensiones

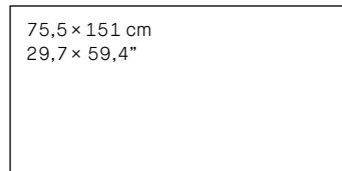

75,5 × 151 cm  
29,7 × 59,4"

40 patterns

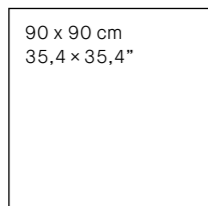

90 × 90 cm  
35,4 × 35,4"

20 patterns

Shade variation: V2

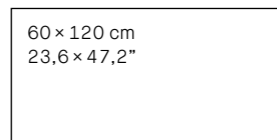

60 × 120 cm  
23,6 × 47,2"

35 patterns

### References / Referencias

References / Referencias	Price code
21070 TORANO BIANCO/75,5x151/EP	M58
21074 TORANO BIANCO/75,5x151/NAT/R	M59
22011 TORANO BIANCO/60x120/EP	M40
22012 TORANO BIANCO/60x120/NAT/R	M66
22061 TORANO BIANCO/90x90/EP	M2
22062 TORANO BIANCO/90x90/NAT/R	M68

### Dimensions / Dimensiones

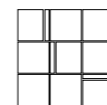

30 × 30 cm  
11,8 × 11,8"

mixed  
finishes  
polished | natural

### References / Referencias

References / Referencias	Price code
22252 D. TORANO BIANCO MOSAIC/30X30	U58

22302 L.ALUMINUM/120/MATT U44 (0,5x120 cm - 0,19x47,2 ")

22314 L.ALUMINUM/120/SHINE U44 (0,5x120 cm - 0,19x47,2 ")



Fidias





Fidias — B

Colors / Colores

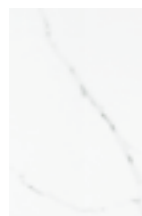

B

Finished / Acabados



premium polished

Decorados / Decors



B

Dimensions / Dimensiones

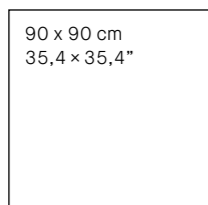

90 x 90 cm  
35,4 x 35,4"

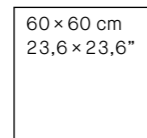

60 x 60 cm  
23,6 x 23,6"

12 patterns

33 patterns

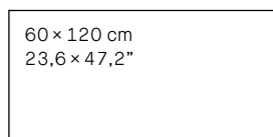

60 x 120 cm  
23,6 x 47,2"

16 patterns

Shade variation: V2

References / Referencias

20121 FIDIAS-B/90x90/EP	M2
11618 FIDIAS-B/60/P	M37
19253 FIDIAS-B/60x120/EP	M-40

Price code

Dimensions / Dimensiones

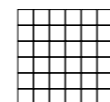

30 x 30 cm  
11,8 x 11,8"

References / Referencias

19548 D. FIDIAS-B/5/EP	U49
* 11832 ROS. ELENA-B/120/P (120x120 cm-47,2x47,2")	U94
11834 C. ELENA-B/60/P (18x60 cm-7,1x23,6")	U77
11833 E. ELENA-B/60/P (18x18 cm-7,1x7,1")	U52
11880 L. FIDIAS-B/60/P (5x60 cm-1,9x23,6")	U28
11882 T. FIDIAS-B/5/P (5x5 cm-1,9x1,9")	U11
11881 L. LUXURY-N/60/P (5x60 cm-1,9x23,6")	U28
11883 T. LUXURY-N/60/P (5x5 cm-1,9x1,9")	U11

Price code

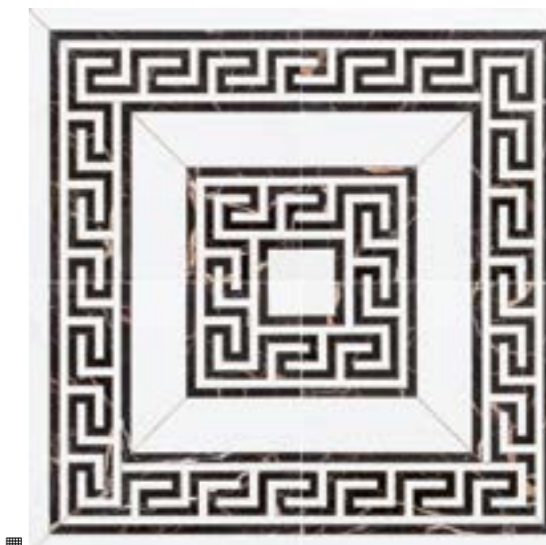

\* 11832

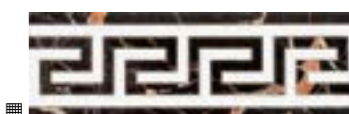

11834



11833



11880



11882

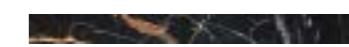

11881



11883

\* Cualquier cambio de color en este rosetón, incrementará su precio de tarifa un 100%.  
Any change of colour of this rosette will increase its tariff price by 100%.



Freeze



## Freeze — W

### Colors / Colores



W

### Finished / Acabados

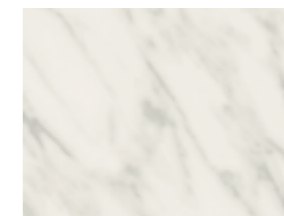

polished

### Dimensions / Dimensiones

90 x 90 cm  
35,4 x 35,4"

32 patterns

60 x 120 cm  
23,6 x 47,2"

18 patterns

Shade variation: V2

### References / Referencias

18672 FREEZE-W/90x90/EP  
18671 FREEZE-W/60x120/EP

### Price code

M2  
M40



Gioia







Gioia — Silver

Gioia — Gold

Colors / Colores



Silver Gold

Finished / Acabados



polished

Decorados / Decors



Silver Gold

Dimensions / Dimensiones

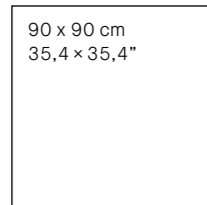

90 x 90 cm  
35,4 x 35,4"

15 patterns

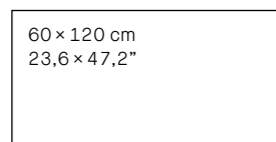

60 x 120 cm  
23,6 x 47,2"

15 patterns

Shade variation: V2

References / Referencias

References / Referencias	Price code
19648 GIOIA SILVER/90x90/EP	M2
19507 GIOIA SILVER/60x120/EP	M40
19647 GIOIA GOLD/90x90/EP	M2
19508 GIOIA GOLD/60x120/EP	M40

Dimensions / Dimensiones

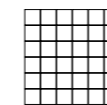

30 x 30 cm  
11,8 x 11,8"

References / Referencias

References / Referencias	Price code
19662 D. GIOIA SILVER/5/EP	U49
19661 D. GIOIA GOLD/5/EP	U49

22314 L.ALUMINUM/120/SHINE U44 (0,5x120 cm - 0,19x47,2 ")

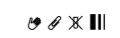



Hettangian floor







Hettangian floor

Colors / Colores



Ivory

Grey

Beige

Finished / Acabados



polished

Dimensions / Dimensiones

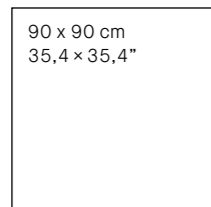

90 x 90 cm  
35,4 x 35,4"

30 patterns

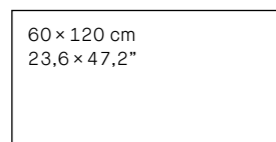

60 x 120 cm  
23,6 x 47,2"

14 patterns

Shade variation: V2

References / Referencias

References / Referencias	Price code
18019 HETTANGIAN-I/90x90/EP	M2
19052 HETTANGIAN-I/60x120/EP	M40
18201 HETTANGIAN-G/90x90/EP	M2
19051 HETTANGIAN-G/60x120/EP	M40
15821 HETTANGIAN-B/90x90/EP	M2

Hettangian floor

Decorados / Decors

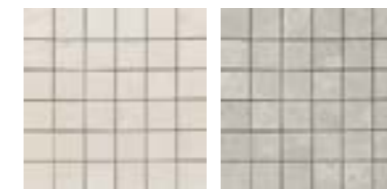

Ivory

Grey

Dimensions / Dimensiones

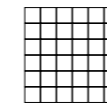

30 x 30 cm  
11,8 x 11,8"

References / Referencias

References / Referencias	Price code
19545 D. HETTANGIAN-I/5/EP	U49
19546 D. HETTANGIAN-G/5/EP	U49
17546 D. HETTANGIAN-B/90/1/EP (90x90 cm-35,4x35,4")	U72
17338 T. I. HETTANGIAN-B/90/EP (41x41 cm-16,1x16,1")	U75
17335 C. HETTANGIAN-B/90/EP (15x90 cm-5,9x35,4")	U69
17336 E. HETTANGIAN-B/90/EP (15x15 cm-5,9x5,9")	U49



17546



X

17338



X

17335

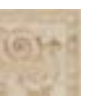

X

17336



Kritios







## Kritios

### Colors / Colores



Kritios

### Finished / Acabados



polished

### Dimensions / Dimensiones

90 x 90 cm  
35,4 x 35,4"

16 patterns

60 x 120 cm  
23,6 x 47,2"

16 patterns

Shade variation: V2

### References / Referencias

20386 KRITIOS/90x90/EP  
20363 KRITIOS/60x120/EP

### Price code

M2  
M40



Madison





## Madison

### Colors / Colores



Madison

### Finished / Acabados

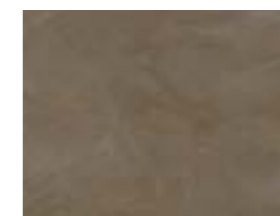

polished

### Dimensions / Dimensiones

90 x 90 cm  
35,4 x 35,4"

10 patterns

60 x 120 cm  
23,6 x 47,2"

18 patterns

Shade variation: V2

### References / Referencias

### Price code

21064 MADISON/90x90/EP  
21065 MADISON/60x120/EP

M2  
M40



Metropolitan floor

BUSINESS  
AREA



Metropolitan floor — B

Metropolitan floor — B

Colors / Colores



B

Finished / Acabados



polished

Decorados / Decors



B

Dimensions / Dimensiones

90 x 90 cm  
35,4 x 35,4"

45 x 90 cm  
35,4 x 35,4"

12 patterns

24 patterns

60 x 120 cm  
23,6 x 47,2"

60 x 60 cm  
23,6 x 23,6"

30 x 60 cm  
11,8 x 23,6"

18 patterns

35 patterns

70 patterns

Shade variation: V3

References / Referencias

Reference	Description	Price code
15829	METROPOLITAN-B/90x90/EP	M2
16703	METROPOLITAN-B/45x90/EP	M2
16777	METROPOLITAN-B/60x120/EP	M40
17089	METROPOLITAN-B/60x60/EP	M4
17307	METROPOLITAN-B/60x60/MAT/R	M60
17540	METROPOLITAN-B/30x60/EP	M4
17587	METROPOLITAN-B/30x60/MAT/R	M64

Dimensions / Dimensiones

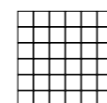

30,2 x 30,2 cm  
11,8 x 11,8"

References / Referencias

Reference	Description	Price code
17596	D.METROPOLITAN-B/5	U49
17547	D.METROPOLITAN-B/90/1/EP (90x90 cm-35,4x35,4")	U72
17372	T. I. METROPOLITAN-B/90/EP (41x41 cm-16,1x16,1")	U75
17370	C. METROPOLITAN-B/90/EP (15x90 cm-5,9x35,4")	U69
17371	E. METROPOLITAN-B/90/EP (15x15 cm-5,9x5,9")	U49
17634	D. ILLINOIS-B/60/EP (60x60 cm-23,6x23,6")	U70



17547



17372

17634



17370



17371



Orio





## Orio — H

Colors / Colores



H

Finished / Acabados



polished

Dimensions / Dimensiones

90 x 90 cm  
35,4 x 35,4"

12 patterns  
Shade variation: V3

References / Referencias

15826 ORIO-H/90/EP

Price code

M2



State



## State — B

### Colors / Colores



B

### Finished / Acabados



polished

### Dimensions / Dimensiones

90 x 90 cm  
35,4 x 35,4"

20 patterns  
Shade variation: V2

### References / Referencias

20120 STATE-B/90x90/EP

### Price code

M2



Stiava





## Stiava

### Colors / Colores



Stiava

### Finished / Acabados



polished

### Dimensions / Dimensiones

90 x 90 cm  
35,4 x 35,4"

13 patterns

60 x 120 cm  
23,6 x 47,2"

17 patterns

Shade variation: V2

### References / Referencias

20385 STIAVA/90x90/EP  
20362 STIAVA/60x120/EP

### Price code

M2  
M40



# Sunshine







## Sunshine — B

Colors / Colores



B

Finished / Acabados

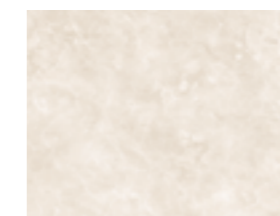

polished

Decorados / Decors

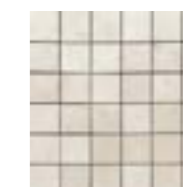

B

Dimensions / Dimensiones

90 x 90 cm  
35,4 x 35,4"

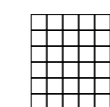

29,9 x 29,9 cm  
11,7 x 11,7"

14 patterns

60 x 120 cm  
23,6 x 47,2"

18 patterns

Shade variation: V2

References / Referencias

Price code

18669 SUNSHINE-B/90x90/EP

M2

18495 SUNSHINE-B/60x120/EP

M40

19550 D. SUNSHINE-B/5/EP

U49



Grevin



## Grevin — H

Colors / Colores



H

Finished / Acabados



polished

Decorados / Decors

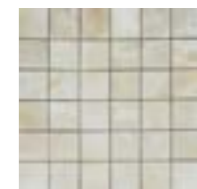

H

Dimensions / Dimensiones

60 × 120 cm  
23,6 × 47,2"

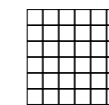

29,9 × 29,9 cm  
11,7 × 11,7"

8 patterns

Shade variation: V3

References / Referencias

Price code

19252 GREVIN-H/60x120/EP

M40

19547 D.GREVIN-H/5/EP

U49



Lens









Lens

Colors / Colores

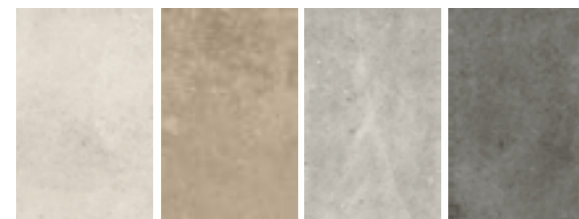

White    Taupe    Silver    Grey

Finished / Acabados



river-washed

Dimensions / Dimensiones

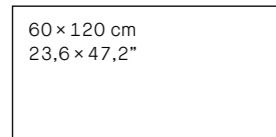

60 × 120 cm  
23,6 × 47,2"

22 patterns

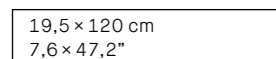

19,5 × 120 cm  
7,6 × 47,2"

66 patterns

Shade variation: V2

References / Referencias

References / Referencias	Price code
22233 LENS WHITE/60x120/RW/R	M66
22237 LENS WHITE/19,5x120/RW/R	M67
22234 LENS TAUPE/60x120/RW/R	M66
22238 LENS TAUPE/19,5x120/RW/R	M67
22232 LENS SILVER/60x120/RW/R	M66
22236 LENS SILVER/19,5x120/RW/R	M67
22231 LENS GREY/60x120/RW/R	M66
22235 LENS GREY/19,5x120/RW/R	M67

Lens

Decorados / Decors



White    Taupe    Silver    Grey

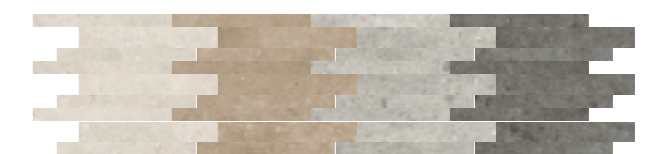

White    Taupe    Silver    Grey

Dimensions / Dimensiones

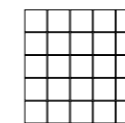

30 × 30 cm  
11,8 × 11,8"



29,8 × 29,2 cm  
11,7 × 11,5"

References / Referencias

References / Referencias	Price code
22776 D. LENS WHITE MOSAIC/30X30/RW	U39
22790 D. LENS WHITE/29,8X29,2/RW	U50
22777 D. LENS TAUPE MOSAIC/30X30/RW	U39
22791 D. LENS TAUPE BRICK/29,8X29,2/RW	U50
22779 D. LENS SILVER MOSAIC/30X30/RW	U39
22792 D. LENS SILVER BRICK/29,8X29,2/RW	U50
22778 D. LENS GREY MOSAIC/30X30/RW	U39
22793 D. LENS GREY BRICK/29,8X29,2/RW	U50





Lumina



## Lumina — B

Colors / Colores



B

Finished / Acabados



premium polished

polished

Decorados / Decors

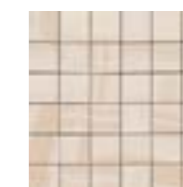

B

Dimensions / Dimensiones

60 × 120 cm  
23,6 × 47,2"

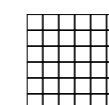

30 × 30 cm  
11,8 × 11,8"

9 patterns

Shade variation: V2

References / Referencias

14295 LUMINA-B/120/P  
19254 LUMINA-B/60x120/EP  
19549 D. LUMINA-B/5/EP

Price code

M46  
M40  
U49



Marq



Marq — H

Colors / Colores



H

Finished / Acabados

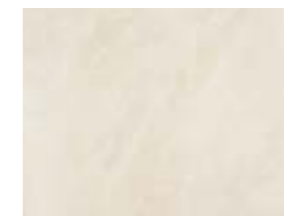

polished

Dimensions / Dimensiones

60 × 120 cm  
23,6 × 47,2"

15 patterns  
Shade variation: V1

References / Referencias

20216 MARQ-H/60x120/EP

Price code

M40



# Menhir



## Menhir — H

### Colors / Colores



H

### Finished / Acabados



premium polished

### Dimensions / Dimensiones

60 × 120 cm  
23,6 × 47,2"

9 patterns

Shade variation: V1

### References / Referencias

16205 MENHIR-G/120/P

### Price code

M46

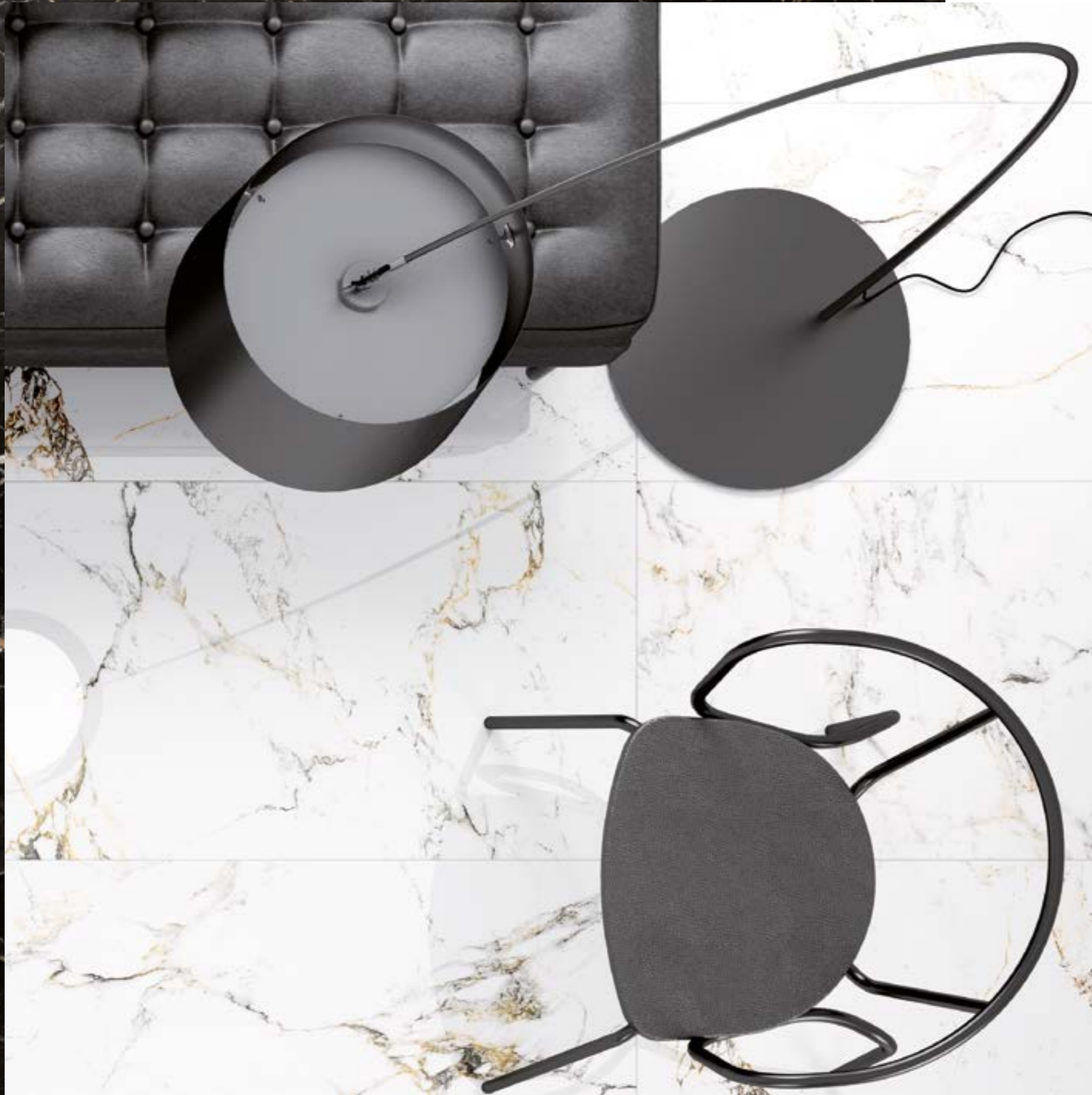

Tucci









Tucci — Black



Tucci — Gold

Colors / Colores



Black

Gold

Finished / Acabados



premium polished

Dimensions / Dimensiones

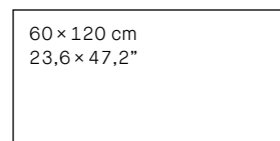

11 patterns

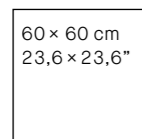

22 patterns

Shade variation: V2

References / Referencias

20387	TUCCI BLACK/60x120/P
20577	TUCCI BLACK/60x60/P
20388	TUCCI GOLD/60x120/P
20578	TUCCI GOLD/60x60/P

Price code

M46
M37
M46
M37

Decorados / Decors



20832



20831

References / Referencias

20832	ROS. TUCCI BLACK/P (120x120 cm-47,2x47,2")
20831	ROS. TUCCI GOLD/P (120x120 cm-47,2x47,2")

Price code

U88
U88



Vogue



## Vogue — B

Colors / Colores



B

Finished / Acabados

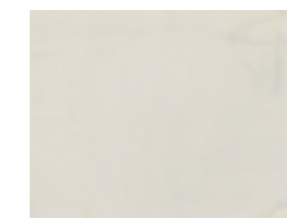

premium polished

Dimensions / Dimensiones

60 × 120 cm  
23,6 × 47,2"

20 patterns  
Shade variation: V1

References / Referencias

12949 VOGUE-B/120/P

Price code

M46



Agatha



## Agatha

### Colors / Colores



H

M

### Finished / Acabados



premium polished

### Dimensions / Dimensiones

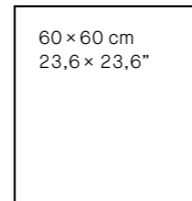

60 × 60 cm  
23,6 × 23,6"

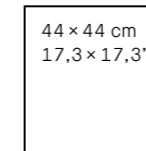

44 × 44 cm  
17,3 × 17,3"

6 patterns

6 patterns

Shade variation: V2

### References / Referencias

### Price code

11892 AGATHA-H/60/P	M-37
11320 AGATHA-H/44/P	M-30
11921 AGATHA-M/60/P	M-37
11322 AGATHA-M/44/P	M-30



Agatha

Decorados / Decors

References / Referencias	Price code
*11955 ROS. FONTAINE/120/P (120x120 cm-47,2x47,2")	U98
*11609 ROS. FONTAINE/88/P (88x88 cm-34,6x34,6")	U84
11624 C. FONTAINE/44/P (10x44 cm-3,9x17,3")	U69
11623 E. FONTAINE/44/P (10x10 cm-3,9x3,9")	U60
11602 C. GINGER-M/44/P (13x44 cm-5,1x17,3")	U69
11604 E. GINGER-M/44/P (13x13 cm-5,1x5,1")	U60
11590 E.D. FONTAINE/44/P (44x44 cm-17,3x17,3")	U90
11591 L.D. FONTAINE/44/P (44x44 cm-17,3x17,3")	U90
08143 T.I. SOFIA/P (29x29 cm-11,4x11,4")	U70
10137 C. SOFIA/60/P (7x60 cm-2,7x23,6")	U85
08146 C. SOFIA/P (7x44 cm-2,7x17,3")	U61
08145 C. LOREN/P (4x44 cm-1,5x17,3")	U52
08147 T. SOFIA/P (7x7 cm-2,7x47,2")	U69
08468 T. LOREN/P (4x4 cm-1,5x47,2")	U64



\*11955



\*11609



11624



11623



11602



11604



11590



11591

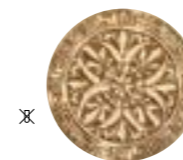

08143



10137



08147



08146



08145



08468

\* Cualquier cambio de color en este rosetón, incrementará su precio de tarifa un 100%. - Any change of colour of this rosette will increase its tariff price by 100%.



# Capital





Capital — B

Colors / Colores



B

Finished / Acabados

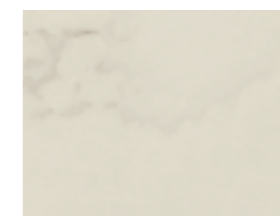

premium polished

Dimensions / Dimensiones

60 × 60 cm  
23,6 × 23,6"

36 patterns  
Shade variation: V2

References / Referencias

16745 CAPITAL-B/60/P

Price code

M37



Macba - Muvim

Macba



Muvim



Macba — Muvim

Colors / Colores



Argent

Finished / Acabados



premium polished

Dimensions / Dimensiones

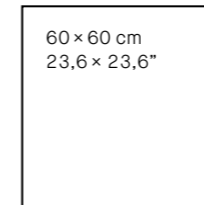

MACBA  
13 patterns  
Shade variation: V2

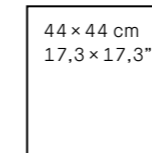

MUVIM  
46 patterns

References / Referencias

Price code

10102 MACBA-M/P  
07801 MUVIM-M/P

M37  
M30



Macba — Muvim

Decorados / Decors



Dimensions / Dimensiones

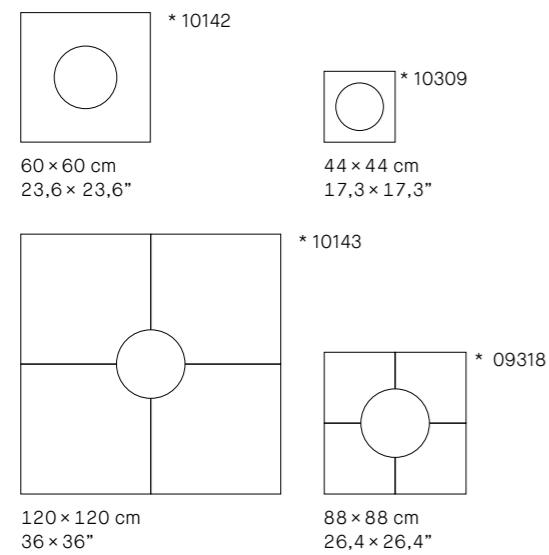

References / Referencias

References / Referencias	Price code
* 10142 D. MACBA-M/1/P (60x60 cm-23,6x23,6")	U61
* 10309 D. MUVIM-M/1/P (44x44 cm-17,3x17,3")	U66
* 10143 D. MACBA-M/4/P (120x120 cm-47,2x47,2")	U86
* 09318 D. MUVIM-M/4/P (88x88 cm-34,6x34,6")	U82
08143 T. I. SOFIA/P (29x29 cm-11,4x11,4")	U70
10137 C. SOFIA/60/P (7x60 cm-2,7x23,6")	U85
08146 C. SOFIA/P (7x44 cm-2,7x17,3")	U61
08145 C. LOREN/P (7x44 cm-2,7x17,3")	U52
08147 T. SOFIA/P (7x7 cm-2,7x47,2")	U69
08468 T. LOREN/P (4x4 cm-1,5x1,5")	U64
* 10168 O.B. MACBA-M/8/P (120x240 cm-47,2x94,4")	U100
* 10247 O.B. MUVIM-M/8/P (88x176 cm-34,6x69,2")	U90
08144 ROS. SOFIA/P (88x88 cm-34,6x34,6")	U63
08719 ROS. LOREN/P (88x88 cm-34,6x34,6")	U83

\* Se fabrica en todos los colores de las bases. They are manufactured in all the colour of the bases.



08144



08719



\*10168

\* El precio corresponde al decorado completo, que se comercializa como una unidad. The price corresponds to the complete decor, that is sold as a whole unit.



\*10247

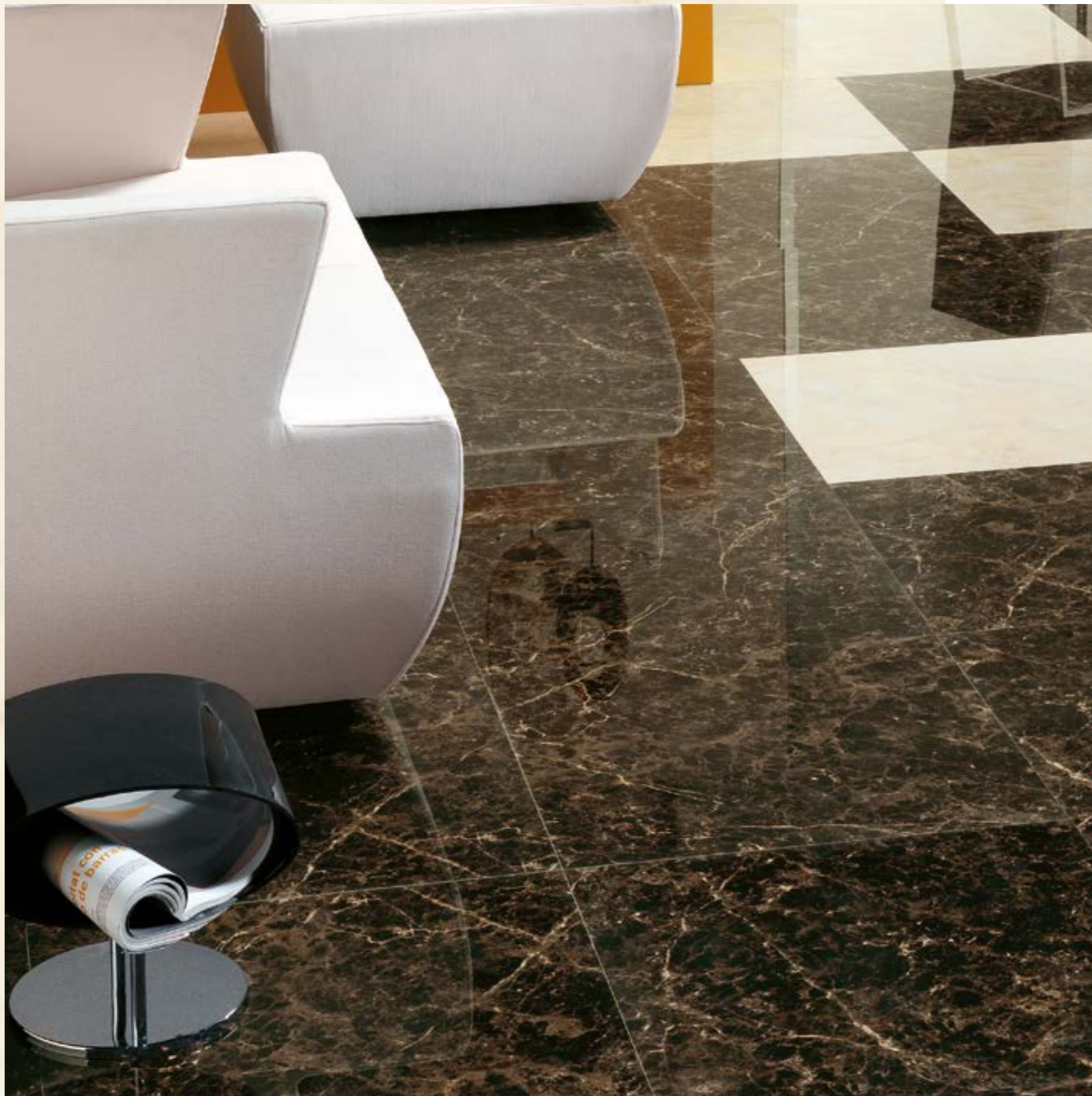

Opalo—Onice  
Bach—Zar



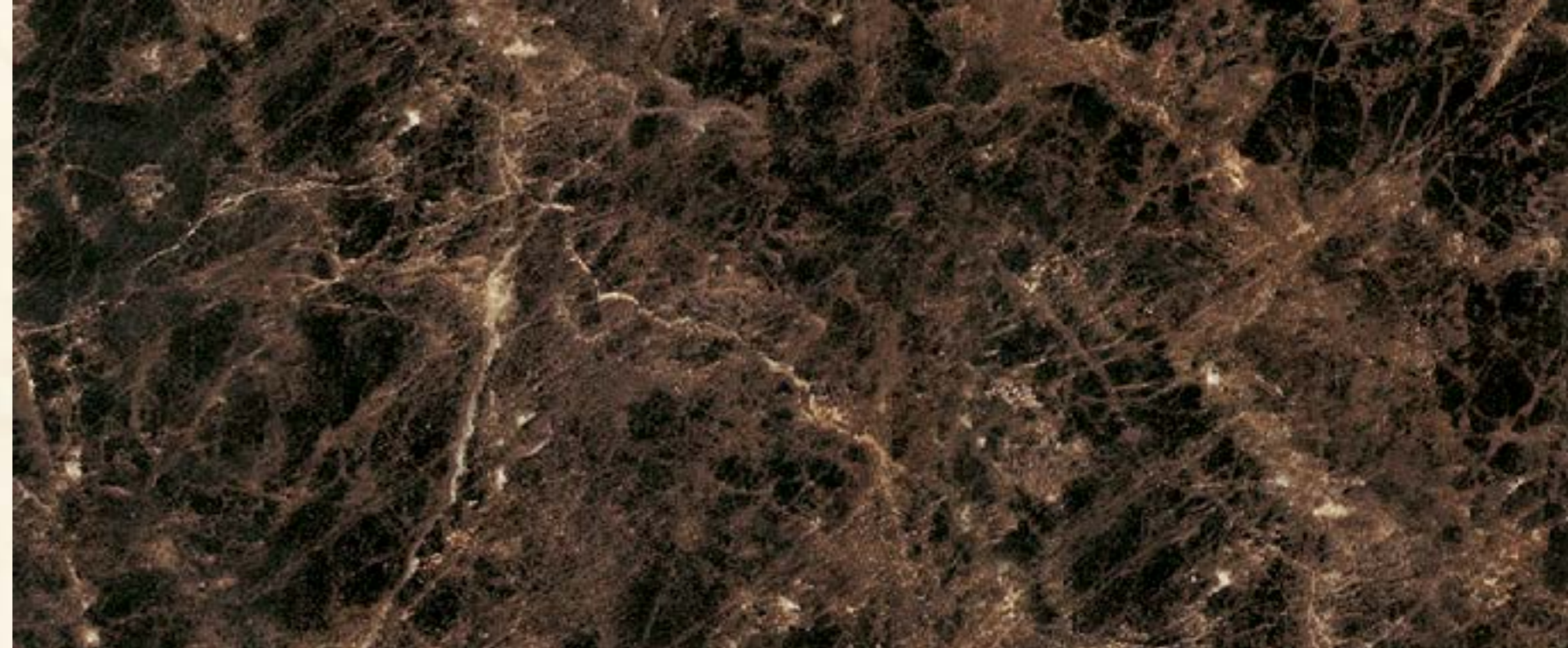

Opalo — Onice

Colors / Colores

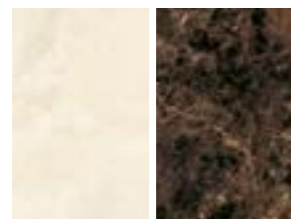

B

M

Finished / Acabados



premium polished

Dimensions / Dimensiones

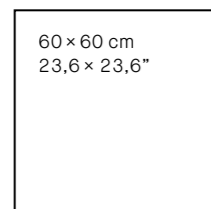

60 x 60 cm  
23,6 x 23,6"

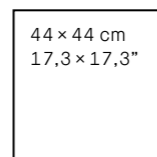

44 x 44 cm  
17,3 x 17,3"

ONICE—ZAR  
12 patterns

References / Referencias

References / Referencias	Price code
07968 OPALO-B/P (60x60 cm-23,6x23,6")	M-37
06468 ONICE-B/P (44x44 cm-17,3x17,3")	M-30
08215 BACH-M/P (60x60 cm-23,6x23,6")	M-37
06427 ZAR-M/P (44x44 cm-17,3x17,3")	M-30

Bach — Zar

Decorados / Decors

References / Referencias

Price code

* 11626 ROS. BEAUTY/P (120x120 cm-47,2x47,2")	U94
* 08156 ROS. CATHERINE/P (88x88 cm-34,6x34,6")	U84
11397 C. BEAUTY/P (18x60 cm-7,1x23,6")	U77
11398 E. BEAUTY/P (18x18 cm-7,1x7,1")	U52



\* 11626



\* 08156

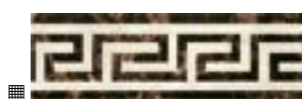

11397



11398

\* Cualquier cambio de color en este rosetón, incrementará su precio de tarifa un 100%. — Any change of colour of this rosette will increase its tariff price by 100%.



# Persepolis





Persepolis — M

Colors / Colores



M

Finished / Acabados



premium polished

Dimensions / Dimensiones

60 × 60 cm  
23,6 × 23,6"

44 × 44 cm  
17,3 × 17,3"

82 patterns

44 patterns

Shade variation: V2

References / Referencias

Price code

12942 PERSEPOLIS-M/60/P  
12961 PERSEPOLIS-M/44/P

M37  
M30



Persepolis — M

Decorados / Decors

References / Referencias	Price code
13348 ESTAMBUL-M/60/P (60x60 cm-23,6x23,6")	M46
13451 CARTAGO-M/44/P (44x44 cm-17,3x17,3")	M43
* 13440 ROS. MUSA-M/120/P (120x120 cm-47,2x47,2")	U99
13442 C. MUSA/1/60/P (22x60 cm-8,6x23,6")	U72
13443 C. MUSA/2/60/P (22x60 cm-8,6x23,6")	U64
13441 E. MUSA/60/P (22x22 cm-8,6x8,6")	U71
* 13220 ROS. MUSA-M/88/P (88x88 cm-34,6x34,6")	U97
13221 C. MUSA/1/44/P (22x44 cm-8,6x17,3")	U87
13222 C. MUSA/2/44/P (22x44 cm-8,6x17,3")	U62
13223 E. MUSA/44/P (22x22 cm-8,6x8,6")	U66
13187 L. PERSEPOLIS-M/60/P (5x60 cm-1,9x23,6")	U28
13188 L. PERSEPOLIS-M/44/P (3x44 cm-1,2x17,3")	U14
13189 T. PERSEPOLIS-M/60/P (5x5 cm-1,9x1,9")	U11
13190 T. PERSEPOLIS-M/44/P	U8



13348



13451



\* 13440



13442



13441



13443



13187



13189



\* 13220



13221



13223



13222



13188



13190

\* Cualquier cambio de color en este rosetón, incrementará su precio de tarifa un 100%. — Any change of colour of this rosette will increase its tariff price by 100%.



Petra



Petra — B

Colors / Colores



B

Finished / Acabados



premium polished

Dimensions / Dimensiones

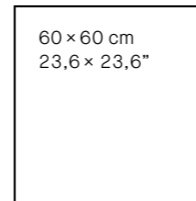

37 patterns

Shade variation: V2

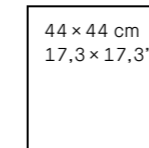

69 patterns

References / Referencias

Price code

12941 PETRA-B/60/P  
12963 PETRA-B/44/P

M37  
M30

Petra — B

Decorados / Decors

References / Referencias

Price code

13357 ESTAMBUL-B/60/P (60x60 cm-23,6x23,6")	M46
13439 CARTAGO-B/44/P	M43
13375 AVARIS/60/P (60x60 cm-23,6x23,6")	M46
13453 AVARIS/44/P (44x44 cm-17,3x17,3")	M43
10543 T.I. GINA/P (29x29 cm-11,4x11,4")	U70
10544 C. GINA/P (4x44 cm-1,5x17,3")	U52
10546 T. GINA/P (4x4 cm-1,5x1,5")	U64
*13402 ROS. MUSA-B/120/P (120x120 cm-47,2x47,2")	U99
13442 C. MUSA/1/60/P (22x60 cm-8,6x23,6")	U72
13443 C. MUSA/2/60/P (22x60 cm-8,6x23,6")	U64
13441 E. MUSA/60/P (22x22 cm-8,6x8,6")	U71
* 13231 ROS. MUSA-B/88/P (88x88 cm-34,6x34,6")	U97
13221 C. MUSA/1/44/P (22x44 cm-8,6x17,3")	U87
13222 C. MUSA/2/44/P (22x44 cm-8,6x17,3")	U62
13223 E. MUSA/44/P (22x22 cm-8,6x8,6")	U66
13193 L. PETRA-B/60/P (5x60 cm-1,9x23,6")	U28
13192 T. PETRA-B/60/P (5x5 cm-1,9x1,9")	U11
13194 L. PETRA-B/44/P (3x44 cm-1,2x17,3")	U14
13191 T. PETRA-B/44/P (3x3 cm-1,2x1,2")	U8



13375 — 8 patterns



13357



13453 — 8 patterns



13439



10543



10544



10546



\*13402



\* 13231



13442



13441



13221



13223



13443

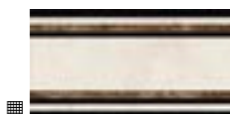

13222



13193



13192



13194



13191

\* Cualquier cambio de color en este rosetón, incrementará su precio de tarifa un 100%. — Any change of colour of this rosette will increase its tariff price by 100%.



Luxury



## Luxury — N

Colors / Colores



N

Finished / Acabados



premium polished

Decorados / Decors



09903



09901



09867

09904

11463

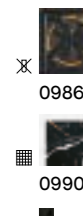

09865

09902

10675

Dimensions / Dimensiones

44 × 44 cm  
17,3 × 17,3"

12 patterns

Shade variation: V2

References / Referencias

References / Referencias	Price code
09676 LUXURY-N/P (44x44 cm-17,3x17,3")	M30
09903 E.D. LUXURY-N/P (44x44 cm-17,3x17,3")	U80
09901 L.D. LUXURY-N/P (44x44 cm-17,3x17,3")	U86
09867 C. ORIENT-N/P (13,5x44 cm-5,3x17,3")	U64
09865 E. ORIENT-N/P (13,5x13,5 cm-5,3x5,3")	U46
09904 C. LUXURY-N/P (10x44 cm-3,9x17,3")	U68
09902 E. LUXURY-N/P (10x10 cm-3,9x3,9")	U53
11463 L. LUXURY-N/P (3x44 cm-1,2x17,3")	U14
10675 T. LUXURY-N/P (3x3 cm-1,2x1,2")	U8



Led





## Led

### Colors / Colores

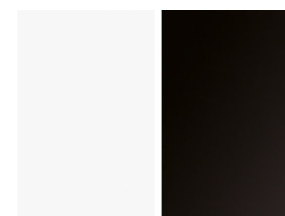

W

N

### Finished / Acabados



premium polished

polished

### Dimensions / Dimensiones

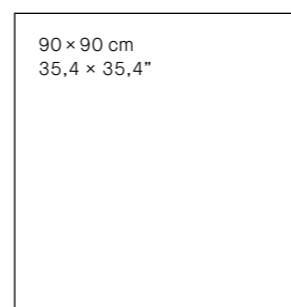

44 x 44 cm  
17,3 x 17,3"

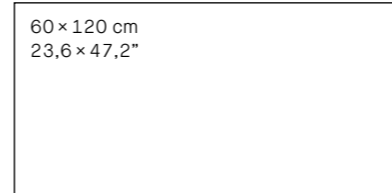

### References / Referencias

### Price code

20311 LED-W/90/EP	M2
20819 LED-W/120/EP	M40
11708 LED-W/44/P	M42
11983 LED-N/44/P	M42

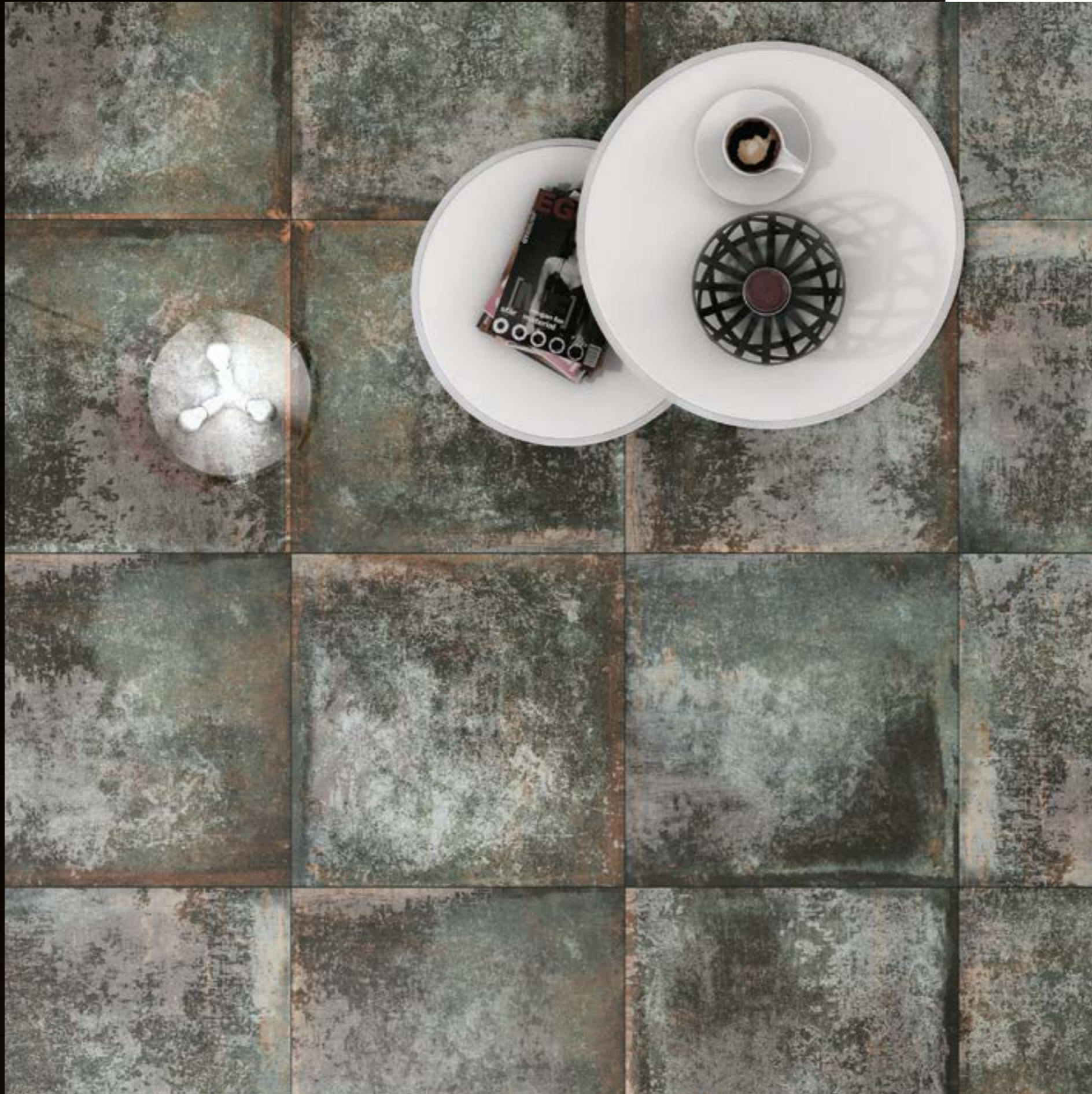

Concept





Concept

Colors / Colores



KROSS-V KROSS-N KURT

Finished / Acabados



premium polished

Dimensions / Dimensiones

60 x 60 cm  
23,6 x 23,6"

KROSS  
10 patterns

KURT  
5 patterns  
Shade variation: V3

References / Referencias

20438 KROSS-V/60x60/P  
20437 KROSS-N/60x60/P  
17233 KURT/60/P

Price code

M46  
M46  
M46



Bansky





Banksy

Colors / Colores



BANSKY

Finished / Acabados



premium polished

Dimensions / Dimensiones

44 × 44 cm  
17,3 × 17,3"

68 patterns  
Shade variation: V4

References / Referencias

09725 BANSKY/P (44x44 cm-17,3x17,3")

Price code

M43

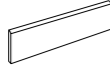
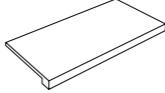
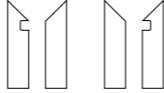
Name - Nombre	SKIRTING RODAPIÉ		TECHNICAL STAIR THREAD PELDAÑO TÉCNICO		S.K.I. S.K.D.	
Shape - Forma						
Size & Price - Formato y precio	8x100 (EP)	U48	30x100	U74	8x30	U53
	8x100 (NAT)	U45	30x100	U74	8x30	U53
	8x90	U44	30x90	U76	8x30	U53
	8x75	U43	30x150	U80	8x30	U55
	8x75,5	U43	30x151 (NAT)	U80	8x30	U53
	8x75,5	U43	30x151 (EP)	U86	8x30	U53
	8x75,5	U43	30x75,5 (NAT)	U70	8x30	U53
	8x75,5	U43	30x75,5 (EP)	U76	8x30	U53
	8x60 (P)	U45	30x120 (P)	U80	8x30 (P)	U55
	8x60	U35	30x120	U75	8x30	U53
	8x60 (P)	U45	30x60 (P)	U82	8x30 (P)	U55
	8x60	U35	30x60	U54	8x30	U53
	8x44	U38	30x44	U87	8x44	U58

Formato - Sizes	Cajas - Boxes			Pallet				Cont./20' 24000 Kg.		
	Piezas	m <sup>2</sup>	kg	Cajas	m <sup>2</sup>	kg	Tamaño cm aprox	Nº pallets	m <sup>2</sup>	kg
100 x 180 x 0,8	2	3,6	66,07	20	72	1371	112 x 181 x 64	17	1224	23313
75,5 x 151 x 1,2	1	1,14	30,70	38	43,32	1211,60	160 x 92 x 76	17	736,44	20597,20
19,5x150 x 0,8	4	1,17	23,10	48	56,16	1153,80	160 x 92 x 54	17	954,72	19614,60
60 x 120 x 1,15	2	1,44	38,30	27	38,88	1059	120 x 80 x 75	22	855	23300
60 x 120 x 1,2 (EP)	2	1,44	38,30	27	38,88	1058	120 x 80 x 75	22	855	23278
60 x 120 x 1,2 (NAT)	2	1,44	38,30	27	38,88	1058	120 x 80 x 75	22	855	23278
19,5 x 120 x 1,15	3	0,70	19,70	50	35	1010	128 x 95 x 75	23	805	23230
100 x 100 x 0,8	2	2	36,80	32	48	925	112 X 100 X 64	26	1248	24055
90 x 90 x 1,15	2	1,62	41,8	20	32,4	861	105 x 95 x 75	27	874,8	23247
90 x 90 x 1,2 (EP)	1	0,81	22,25	36	29,16	826	105 x 95 x 75	29	846	23954
90 x 90 x 1,05 (NAT)	1	0,81	21	40	32,40	865	105 x 95 x 75	27	875	23355
50 x 100 x 0,8	3	1,50	28,20	24	36	702	120 X 80 X 66	33	1188	23159
60 x 60 x 1,2	3	1,08	29,64	30	32,40	914	120 x 80 x 75	26	842	23769
60 x 60 x 1	3	1,08	24,11	36	38,88	893	120 x 80 x 75	26	1011	23218
45 x 90 x 1,05	2	0,81	19,19	36	28,92	639	100 x 100 x 59	37	1070	23646
44 x 44 x 1,05	5	0,97	23,20	64	62,08	1510	120 x 80 x 102	15	931	22647
30 x 60 x 0,95	5	0,90	18,70	48	43,20	923	120 x 80 x 75	26	1123	23998
inch	Units	sq ft	lb	Boxes	sq ft	lb	Sizes inch approx.	Nº pallets	sq ft	lb
39,3 x 70,8 x 0,31	2	10,76	145,65	20	775	3022,53	44,1 x 71,2 x 25,2	17	2698,45	250939,04
29,7 x 59,4 x 0,47	1	12,27	67,54	42	466,29	2665,52	62,9 x 36,2 x 29,9	17	7926,97	45313,84
7,6 x 59 x 0,31	4	12,59	50,82	48	604,50	2538,36	62,9 x 36,2 x 21,2	17	10276,51	43152,12
23,6 x 47,2 x 0,45	2	15,50	84,43	27	418,50	2334,69	47,2 x 31,4 x 29,5	22	9203,14	51367,70
23,6 x 47,2 x 0,47 (EP)	2	15,50	84,26	27	418,50	2327,60	47,2 x 31,4 x 29,5	22	9203,13	51211,6
23,6 x 47,2 x 0,47 (NAT)	2	15,50	84,26	27	418,50	2327,60	47,2 x 31,4 x 29,5	22	9203,13	51211,6
7,6 x 47,2 x 0,45	3	7,53	43,34	50	376,74	2222	50 x 37,4 x 29,5	23	8664,94	51106
39,3 x 39,3 x 0,35	2	21,53	80,96	24	516,67	2035	44,1 x 39,3 x 25,2	26	13433,35	52921
35,4 x 35,4 x 0,45	2	17,43	92,15	20	348,75	1898,18	41,3 x 37,4 x 29,5	27	9416,25	51250,86
35,4 x 35,4 x 0,47 (EP)	1	8,72	48,95	36	313,88	1817,20	41,3 x 37,4 x 29,5	29	9106,26	52698,8
35,4 x 35,4 x 0,43 (NAT)	1	8,72	46,20	40	348,75	1903	41,3 x 37,4 x 29,5	27	9418,41	51381
19,6 x 39,3 x 0,31	3	16,15	62,04	24	387,50	1544,40	47,2 x 31,5 x 25,9	33	12787,51	50949,8
23,6 x 23,6 x 0,47	3	11,63	65,21	30	348,75	2010,80	47,2 x 31,4 x 30,3	26	9063,20	52291,8
23,6 x 23,6 x 0,39	3	11,63	53,04	36	418,50	1964,60	47,2 x 31,4 x 29,5	26	10882,30	51079,6
17,7 x 35,4 x 0,41	2	8,72	42,22	32	311,29	1405,80	47,2 x 31,4 x 44,4	37	11517,37	52021,2
17,3 x 17,3 x 0,41	5	10,44	51,04	64	668,22	3322	39,3 x 39,3 x 23,2	15	10021,19	49823,4
11,8 x 26,6 x 0,37	5	9,69	41,14	48	465	2030,60	47,2 x 31,4 x 30,3	26	12087,86	52795,6



# TECHNICAL INFORMATION

## CERTIFICATIONS AND AWARDS



Es una Declaración Ambiental de Producto de conformidad con la Norma UNE-EN ISO 14025 que proporciona información medioambiental basada en el ciclo de vida de nuestros productos.

An Environmental Product Declaration in compliance with the UNE-EN ISO 14025 standard, which provides environmental information based on the lifecycle of our products.

Umwelt-Produktdeklaration gemäß der Norm UNE-EN ISO 14025, die Umweltdaten basierend auf der Lebensdauer unserer Produkte enthält.

Il s'agit d'une Déclaration environnementale de produit conforme à la Norme UNE-EN ISO 14025 qui fournit une information environnementale basée sur le cycle de la vie de nos produits.

Настоящая Экологическая декларация удостоверяет соответствие продукции требованиям международного стандарта ИСО 14025 по представлению информации, полученной на основе оценки жизненного цикла наших изделий.



Sistema de certificación de edificios sostenibles desarrollado por el US Green Building. Nuestros productos pueden contribuir a la obtención de puntos para la obtención de la certificación LEED.

A sustainable building certification system developed by US Green Building. Our products can contribute to the obtainment of points for a LEED certificate.

Zertifizierungssystem für nachhaltige Gebäude, ausgearbeitet von US Green Building. Mit unseren Produkten können Sie Punkte zum Erhalt der LEED-Zertifizierung bekommen.

Système de certification de bâtiments durables mis au point par l'US Green Building. Nos produits peuvent contribuer à l'obtention de points pour la certification LEED.

Система сертификации «зеленого строительства», разработанная Американским Советом по Зеленым Зданиям. Наша продукция помогает получить баллы при сертификации LEED.



Declara la conformidad de nuestros productos con los requisitos establecidos en el Mercado CE que establece que un producto es evaluado antes de ser introducido en el mercado y que cumple con los requisitos de seguridad, salud y protección medioambiental aplicables.

This declares that our products comply with the stipulations of the CE marking, under which a product must be assessed before it is put on sale and comply with the applicable health, safety and environmental requirements.

Erklärt die Konformität unserer Produkte mit den für die CE-Kennzeichnung festgelegten Anforderungen, die bestimmen, dass ein Produkt vor seiner Lancierung auf den Markt bewertet wird und die geltenden Anforderungen bezüglich Sicherheit, Gesundheit und Umweltschutz erfüllt.

Ce signe garantit la conformité de nos produits dans le respect des exigences établies en vertu du Marquage CE selon lequel un produit est évalué avant d'être introduit sur le marché et satisfait les exigences de sécurité, santé et protection applicables sur le plan environnemental.

Подтверждает соответствие продукции требованиям маркировки CE. Перед выходом на рынок изделие проходит проверку на соответствие директиве ЕС о безопасности потребителей и охране здоровья и окружающей среды.



El Certificado CCC es un sistema de certificación obligatorio para las exportaciones a China que garantiza que los productos con baja absorción de agua (E<0.5%) cumplen con los requisitos aplicables de seguridad y calidad establecidos.

The CCC certificate is compulsory for products exported to China. It guarantees that products with a low water absorption rate (E<0.5%) comply with the applicable safety and quality requirements.

Das CCC-Zertifikat ist ein obligatorisches Zertifizierungssystem für Exporte nach China, mit dem gewährleistet wird, dass die Produkte mit geringer Wasseraufnahme (E<0,5 %) die festgelegten geltenden Anforderungen bezüglich Sicherheit und Qualität erfüllen.

Le Certificat CCC est un système de certification obligatoire pour les exportations vers la Chine, qui garantit que les produits à faible absorption d'eau (E<0,5%) satisfont les exigences applicables établies en matière de sécurité et de qualité.

Сертификат CCC является обязательным для экспорта продукции в Китай. Он гарантирует, что продукция с низким водопоглощением (E<0.5%) удовлетворяет требованиям к безопасности и качеству, установленным системой сертификации.



Etiqueta medioambiental para el mercado francés que informa sobre el contenido en COV's (Compuestos Orgánicos Volátiles). Declara que nuestros productos son de tipo A+, contribuyendo a un hábitat sano y respetuoso con el medioambiente.

An environmental label for the French market, which provides information on the VOC content (volatile organic compounds). It declares that our products are rated A+, contributing to a healthy environmentally-friendly habitat.

Umweltetikett für den französischen Markt, der über den Inhalt an VOC (flüchtige organische Verbindungen) informiert. Zertifiziert, dass unsere Produkte zum Typ A+ gehören und zu einem gesunden und umweltfreundlichen Habitat beitragen.

Étiquette environnementale pour le marché français qui informe de la teneur en COV (Composés organiques volatils). Elle déclare que nos produits sont de type A+ et contribuent à un habitat sain et respectueux envers l'environnement.

Экологическая этикетка, предназначенная для французского рынка. Информировает о содержании ЛОС (летучих органических соединений). Свидетельствует о том, что наша продукция относится к типу A+, способствуя поддержанию здоровой и экологически чистой среды обитания.

## Technical information

UNE-EN.14411:2016 Norma - Norm		Gres porcelánico Porcelain tiles		
		ANEXO-ANNEX G		
UNE-EN-ISO 10545		GRUPO-GROUP Bla		
		7 ≤N<15 cm	N≥15 cm	
Longitud y anchura - Length and width		± 0,9 mm	± 0,6 %	± 2,0 mm
		Valor declarado - Declared value		
Espesor - Thickness	Desviación W Desviation W	± 0,5mm	± 5%	± 0,5 mm
Rectitud de lados - Straightness of sides		± 0,75 mm	± 0,5 %	± 1,5 mm
-2 Ortogonalidad - Rectangularity		±0,75 mm	± 0,5 %	± 2,0 mm
	Central - Centre	± 0,75 mm	± 0,5 %	± 2,0 mm
	Lateral - Edge	± 0,75 mm	± 0,5 %	± 2,0 mm
Curvatura Curvature	Alabeo - Warpage	± 0,75 mm	± 0,5 %	± 2,0 mm
Aspecto superficial - Surface quality		95%		
-3 Absorción de agua - Water absorption		≤ 0,5 %		
-4 Fuerza de rotura en N Breaking strength, in N	e ≥ 7,5 mm	≥ 1300 N		
	e < 7,5 mm	≥ 700 N		
Resistencia a la flexión N/mm² - Modulus of rupture, in N/mm²		Media-Average ≥ 35		
-9 Resistencia al choque térmico - Thermal shock resistance		Cumple - Pass		
-11 Resistencia al cuarteo - Crazing resistance		Cumple - Pass		
-12 Resistencia a la helada - Frost resistance		Cumple - Pass		
-13 Resistencia a ácidos y bases Resistance to acids and alkalis	Baja concentración Low concentration	Valor declarado - Declared value		
	Alta concentración High concentration	Valor declarado - Declared value		
Productos domésticos y sales para piscinas Household chemicals and swimming pool salts		mín GB		
-14 Resistencia a las manchas - Resistance to stains		Mínimo clase - Minium class 3		
EN-101 Dureza Mohs - Hardness (Mohs scale)		Valor declarado - Declared value		
Resistencia al deslizamiento - Slip resistance		Cuando se exija - When required		

## Technical information

### (ES) APUNTES DE COLOCACIÓN

La serie Museum está rectificada, con lo que su máxima belleza se obtiene eliminando las juntas entre piezas. Sin embargo, en habitáculos con grandes contrastes de temperaturas, se recomienda colocar las piezas a 0,5 cm de las paredes (que quedará tapado por el rodapié), y crear juntas de dilatación cada 9 m². Es necesario colocarlo sobre una superficie plana, procurando que no se ensucie la superficie con exceso de adhesivos. Por ser un material rectificado, el manejo y la colocación debe ser cuidadosa, evitando golpes entre piezas que puedan dañar las aristas.

Para evitar problemas con el microproo superficial, aconsejamos no marcar con lápiz ni con rotulador la superficie de las baldosas.

Recomendamos, antes de la colocación extender varias piezas, ocupando una superficie de al menos 9 m², para ver cuál sería el efecto estético final.

También es importante recordar que se deben coger piezas de varias cajas, para ver mejor el efecto de mezcla.

Peronda recomienda para cortar este material, máquinas eléctricas con discos para porcelánico, refrigerado por agua, para los cortes rectos y radial para los curvos.

La serie Museum la servimos protegida con una cera especial para su manipulación al colocarlo. Dicha cera se elimina fácilmente con un paño humedecido con alcohol de quemar.

En los rectificados se recomienda dejar una junta mínima de 0.5 mm.

#### ACONSEJAMOS

- Utilizar su cemento cola específico.
- El golpeo para macizar e igualar las piezas debe realizarse con la maza de goma blanca, nunca de color negro o gris.
- Una vez rejuntado el material debe procederse a la limpieza del mismo con una esponja húmeda, antes del endurecimiento definitivo de los materiales de rejuntado.
- Deberá protegerse con cualquier medio adecuado para garantizar que el brillo no se raye o deteriore mientras dure la obra.

### (EN) RECOMMENDATIONS FOR INSTALLATION

The Museum series has a rectified finish, which enables joint-free installation that heightens the beauty of pieces. Nevertheless, in rooms where there are significant temperature contrasts, it is recommended that pieces be installed at a distance of 0.5 cm. from walls (which will be covered by the skirting) and for expansion joints to be rendered every 9 m². It is necessary to install tiles on a flat surface, making sure not to apply adhesive in excess on the surface. Because these are rectified tiles, they must be carefully installed, preventing pieces from colliding together, which may chip edges. In order to prevent problems with the micro-pores on the tile surface, we advise against marking them with a pencil or marker pen.

Before actual installation, we recommend laying out several pieces to cover a surface area of at least 9 m², in order to get an idea of what the final aesthetic effect will be. It is also important to mix together pieces from different boxes, in order to achieve a better overall effect. For cutting these types of tiles, Peronda recommends the use of electric water-cooled cutting machines fitted with discs apt for porcelain tiles for straight cuts; and a radial saw for curves.

The Museum series comes from the factory with a special wax that protects it during installation. This wax is easily removed with a cloth dampened with rubbing alcohol. For tiles with a rectified finish, the minimum recommended joint width is 0.5 mm

#### WE RECOMMEND

- To use a specific adhesive cement appropriate for this kind of tile.
- Use a white rubber mace (never black or grey) to even up the tile surface.

- Once the tiles have been jointed they must be cleaned with a wet sponge before the joint material has fully hardened.
- Tiles must be protected by any suitable means to make sure that the glossy surface would not be scratched or damaged the time the works are carried out.

### (FR) REMARQUES RELATIVES À LA POSE

La série Museum est rectifié, on peut encore optimiser sa grande beauté sans joints entre les pièces. Cependant, dans les espaces caractérisés par d'importants contrastes de températures, il est recommandé de poser les pièces à 0,5 cm des murs (les plinthes dissimulent les creux), ainsi que de prévoir des joints de dilatation tous les 9 m². Il est nécessaire de procéder à la pose sur une surface plane en évitant de tacher la surface des pièces d'excédents de colles. Puisqu'il s'agit d'un matériau rectifié, il convient de le manipuler et de le poser avec le plus grand soin, en évitant les coups entre les pièces, ce qui peut endommager leurs arêtes. Afin d'éviter des problèmes avec les pores microscopiques de la surface des pièces, il est souhaitable de ne pas marquer celle-ci au crayon ou au feutre.

Avant de procéder à la pose, nous conseillons de disposer plusieurs pièces sur le sol, de manière à créer une surface d'au moins 9 m², pour se faire une idée du résultat esthétique final. Il est également important de choisir des pièces provenant de cartons différents pour mieux apprécier l'effet du mélange. Pour couper ce matériau, Peronda recommande d'utiliser des machines électriques et des disques pour le grès cérame, avec refroidissement à l'eau, pour les coupes droites, et une disqueuse pour les coupes courbes.

La série Museum est fournie revêtue d'une cire spéciale chargée de la protéger pendant les opérations de pose. Cette cire s'élimine facilement à l'aide d'un linge imprégné d'alcool à brûler. Dans le cas des carreaux céramiques rectifiés, il est conseillé de prévoir un joint minimum de 0,5 mm.

#### RECOMMANDER

- Utilisation du mortier colle spécifique pour le grès cérame.
- Le coup à appliquer pour tasser et ajuster les pièces doit être donné au moyen d'un maillet en caoutchouc blanc, en aucun cas de couleur noire ou grise.
- Le jointoiement une fois achevé, il est nécessaire de procéder au nettoyage du matériau au moyen d'une éponge humide, et ce avant le durcissement définitif des matériaux de jointoiement.
- Les pièces doivent être protégées par un moyen adéquat quelconque de manière à d'éviter qu'elles ne perdent leur brillant, qu'elles ne se rayent ou ne se détériorent pendant les travaux.

### (GE) ANMERKUNGEN ZUR VERLEGUNG

Die Serie Museum ist kalibriert. Deshalb erzielt man die schönsten Effekte, wenn sie ohne Fugen zwischen den Teilen verlegt wird. In Räumen mit starken Temperaturschwankungen wird jedoch empfohlen, die Fliesen mit einem Abstand von 0,5 cm von den Wänden (der von der Fußleiste abgedeckt wird) zu verlegen und alle 9 m² Dehnfugen auszubilden. Die Fliesen müssen auf einer ebenen Fläche verlegt werden, wobei darauf geachtet werden sollte, dass die Fläche nicht durch überschüssigen Kleber verschmutzt wird. Da es sich um kalibriertes Material mit geschliffenen Kanten handelt, muss es sehr sorgfältig behandelt und verlegt werden. Vermeiden Sie, dass die Teile aneinanderstoßen, da dies die Kanten beschädigen könnte.

Um Probleme mit den Mikroporen der Oberfläche zu vermeiden, sollte die Fliesenoberfläche nicht mit Bleistift oder Filzstift markiert werden.

Wir empfehlen, vor dem Verlegen mehrere Teile auf einer Fläche von mindestens 9 m² auszulegen, um das endgültige Aussehen abschätzen zu können.

Bitte vergessen Sie auch nicht, Teile aus verschiedenen Kartons zu nehmen, um die Wirkung der Mischung besser zu sehen.

Peronda empfiehlt zum Schneiden dieses Materials wassergekühlte elektrische Scheibenschneider für Feinstzeug für gerade Schnitte und Radialschneider für runde Schnitte zu verwenden.

Wir liefern die Serie Museum mit einem Schutz aus Spezialwachs zur Behandlung beim Verlegen. Dieses Wachs kann anschließend leicht mit einem mit Spiritus angefeuchteten Tuch entfernt werden.

Bei kalibrierten Teilen sollte eine Fuge von mindestens 0,5 mm vorgesehen werden.

#### EMPFEHLEN

- Für Feinsteinzeug muss der entsprechende spezielle Zementkleber verwendet werden.
- Um die Teile festzuklopfen und ihre Position anzugleichen, muss ein weißer Gummihammer benutzt werden, keinesfalls ein schwarzer oder grauer.
- Wenn das Material verfugt ist, muss es mit einem feuchten Schwamm gereinigt werden, bevor das Fugenmaterial vollständig getrocknet ist.
- Das Feinsteinzeug muss mit irgendeinem geeigneten Mittel geschützt werden, damit während des Verlegens der Glanz nicht verkratzt oder beschädigt wird.

### (RU) СОВЕТЫ ПО УКЛАДКЕ

Серия Museum включает в себя и выверенные по размерам изделия. Максимальный эффект применения такой плитки достигается при укладке без шва. Тем не менее в помещениях с сильными перепадами температуры рекомендуется укладывать изделия на расстоянии 0,5 смот стен, прикрывая образовавшийся промежуток плитнусом, с температурными швами каждые 9 м².

Такую плитку следует укладывать на ровной поверхности, стараясь не пачкать ее излишками клеящих веществ. Так как речь идет о материале с выверенной кромкой, обращение с изделиями должно быть очень осторожным. Следует избегать ударов и столкновений между плитками. Это может привести к образованию сколов. Во избежание осложнений с поверхностной микропорой, советуем не чертить на поверхности плитки ни карандашом, ни фломастером.

Перед укладкой мы рекомендуем разложить плитку на площади, равной, по меньшей мере 9 м², чтобы проверить эстетический эффект. Также необходимо помнить, что изделия должны доставаться одновременно из разных коробок, чтобы эффект смешивания был больше заметен.

Peronda рекомендует использовать для прямой резки этого материала электрические пилы с дисками для керамического гранита и системой водяного охлаждения. Для неровной резки лучше применять циркулярную пилу.

Серия Museum поставляется с защитным слоем воска для предохранения при укладке. Этот слой снимается просто с помощью мягкой тряпки, смоченной в спирте.

Для обрезной плитки рекомендуется оставлять швы размером, по меньшей мере, 0,5мм.

#### МЫ РЕКОМЕНДУЕМ

- Для укладки керамогранита использовать специально предназначенный для такого материала клей
- Постукивание для наполнения пустот и подгонки деталей необходимо осуществлять только белым резиновым молоточком, а не чёрным или серым.
- После заливки швов вовремя почистить швы мокрой губкой до полного затвердения заливочного материала.
- Всеми имеющимися адекватными средствами гарантировать сохранность блеска и предотвратить появление полос и другого брака до завершения строительных работ.

### (ES) CONSEJOS DE COLOCACIÓN

#### CONSEJOS GENERALES

- Se recomienda nivelar las superficies antes de la aplicación de los productos ad-hesivos (morteros, cementos cola, etc.)
- Es necesario respetar las juntas estructurales, perimetrales y de dilatación.
- Para el corte se aconseja la utilización de cortadora eléctrica refrigerada por agua, con discos para porcelánico. Para hacer agujeros en el porcelánico, tratándose de un material tan duro, es necesario hacerlo del siguiente modo:
  - 1.- Utilizar brocas para porcelánico.
  - 3.2.- No utilizar percutor en el taladro.
  - 3.3.- Taladrar a baja revolución.
  - 3.4.- Comenzar por una broca fina y taladrar posteriormente con la broca final.
  - 3.5.- Refrigerar la broca con agua mientras se taladra.
- Como norma no utilicen productos abrasivos. Para la limpieza usen agua y jabón. Si desea utilizar algún producto químico, le recomendamos realizar una prueba en algún lugar no visible. En cualquier caso, consulte nuestro catálogo.
- No mojar las piezas antes de su colocación. Las piezas de producto rectificado siempre se colocan en seco para evitar posibles deformaciones del material.
- Previamente a la colocación del producto rectificado, la pared debe estar maestraada, es decir a plomo, con mortero. El tiempo mínimo de fraguado de dicha superficie debe ser de 2-3 días.
- Una vez el mortero esté completamente seco, se debe aplicar con llana dentada el cemento cola. Se debe seguir con todo rigor las instrucciones de amasado y colocación indicadas por el fabricante en el propio envase de producto.
- Proteger los pavimentos del tránsito prematuro durante la fase de endurecimiento.
- Una vez colocadas todas las piezas y seco el cemento cola, se procederá al rejuntado con el mortero de rejuntar y llana de goma. Se debe seguir con todo rigor las instrucciones de amasado y colocación indicadas por el fabricante en el propio envase de producto.

#### COLOCACIÓN EN SUELOS CON CALEFACCIÓN RADIANTE

Debido a los fenómenos de transmisión de calor y de dilatación-contracción que puede sufrir el pavimento y que son inherentes a estas instalaciones, se recomienda una disposición de la instalación como se muestra en la figura, donde las capas a aplicar y sus espesores estimados serían (según leyenda):

- A) Pavimento cerámico PERONDA (10 mm aprox)  
B) Capa de cemento cola, adecuado para el tipo de pavimento PERONDA que haya adquirido. (5 mm aprox)  
C) Capa de mortero que albergará las tuberías de calefacción. (40 mm aprox)  
D) Tuberías de calefacción. (dentro de la capa de mortero)  
E) Capa de aislamiento, normalmente compuesta por polietileno y poliestireno expandido. (20 mm aprox)

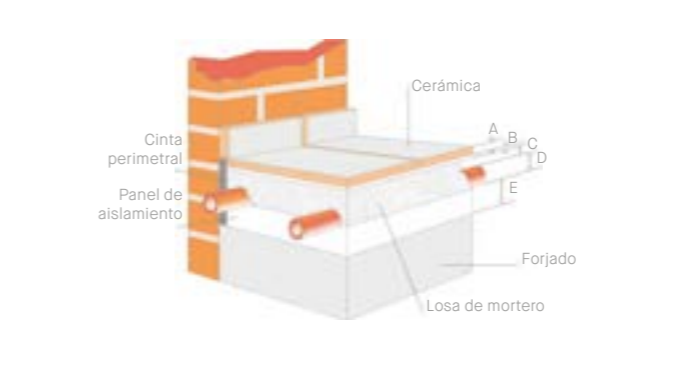

Es necesaria la instalación de una junta perimetral desolidarizante, habitualmente compuesta de polietileno, con el objeto de evitar que las posibles dilataciones o contracciones transmitan esfuerzos mecánicos a las paredes. Es recomendable añadir una capa de film de polietileno de unos 0.15 mm entre la capa de aislamiento (E) y la capa de mortero con las tuberías (C-D), para aumentar el rendimiento de transmisión de calor en la dirección deseada. Asimismo PERONDA también recomienda instalar sobre la capa de mortero y bajo la cerámica una fina lámina de polietileno, de modo que actúe como capa de impermeabilización, como compensación de la presión de vapor que pudiese generarse en caso de aparición de humedad en el soporte y como capa de desolidarización sobre soportes críticos. En el caso de instalaciones de superficie mayor de 40 m o cuando la longitud exceda el doble de la anchura de la estancia, se recomienda la previsión de juntas de dilatación adicionales con las mismas características que la junta perimetral de polietileno.

PERONDA recomienda en caso de desear este tipo de solución constructiva para la calefacción, la realización de un proyecto por técnico especializado para un buen funcionamiento de la instalación.

#### USO Y MANTENIMIENTO

La duración de una superficie depende del modo en que se utiliza y se mantiene. El pavimento nunca es el último elemento a colocar en la obra, con lo que después de colocado es necesario protegerlo de posteriores agresiones, tapándolo bien con plásticos o cartones.

#### LIMPIEZA HABITUAL

Para la limpieza habitual de los pavimentos aconsejamos el empleo de un detergente neutro con alto poder limpiador como FilaCleaner, evitando productos ácidos y abrasivos.

Algunos tipos de suciedad (gravilla, arena...), aumentan el efecto abrasivo del paso de las personas. Por tanto se aconseja mantener el pavimento lo más limpio posible, protegiendo las entradas a las zonas de paso con felpudos. Los pavimentos cerámicos, poseen una resistencia a los golpes moderada. Por tanto, hay que evitar, en la medida de lo posible, la caída de objetos pesados o punzantes, en aquellas zonas de la casa donde esa caída puede ser más habitual.

### (EN) LAYING INSTRUCTIONS

#### GENERAL INSTRUCTIONS

- We would recommend to get the surfaces levelled before using adhesive products (mortars, adhesive cements, etc).
- Structural, perimeter and dilatation joints need to be respected.
- For the porcelain body tiles cutting, we would recommend to use a water cooled electric cutting machine with special discs for porcelain tiles. To drill holes on porcelain body tiles and since it is a very hard material, please proceed as follows:
  - 3.1.- Use drills meant for porcelain tiles.
  - 3.2.- Do not use hammer action drill.
  - 3.3.- Drill at a low revolution.
  - 3.4.- Begin by using a thin bit and finish by drilling with a final bit.
  - 3.5.- Cool the bit down with water while drilling.
- As a general rule, do not use abrasive products. Use water and soap to clean tiles. If you wish to use any chemical product, we would recommend to test it on a place aside. In any case, please consult our catalogue.
- Do not wet tiles before laying them. Rectified tiles always have to be dry laid to avoid possible material defacement.
- Before laying rectified tiles the wall has to be plumb levelled with mortar. It must take a minimum of 2 or 3 days must be allowed to solidify.
- Once the mortar is completely dry, adhesive cement has to be outspraid with a jagged trowel. Strictly follow the manufacturer’s kneading and laying instructions indicated on the product package.
- Floor tiles have to be protected from traffic during the hardening stage.
- Once all the tiles have been laid and the adhesive cement has dried, jointing has to be carried out with joint mortar and a rubber mace. Strictly follow the manufacturer’s kneading and laying instructions indicated on the product package.

#### LAYING INSTRUCTIONS FOR FLOORS WITH RADIANT HEATING

Due to warmth transmission and dilatation/contraction that the floor can suffer, both phenomena inherent to this kind of installations, it is recommended to arrange laying as it is shown in the figure, where layers to be applied as well as their estimated thicknesses would be (according to key):

- A) PERONDA floor tile (10 mm. approx)  
B) Layer of an adhesive cement suitable for PERONDA floor tile you have acquired (5 mm. approx)  
C) Mortar layer that will accommodate heating pipes (40 mm. approx)  
D) Heating pipes (inside the mortar layer)  
E) Insulation layer, which is usually made up of polythene and expanded polystyrene (20 mm. approx)

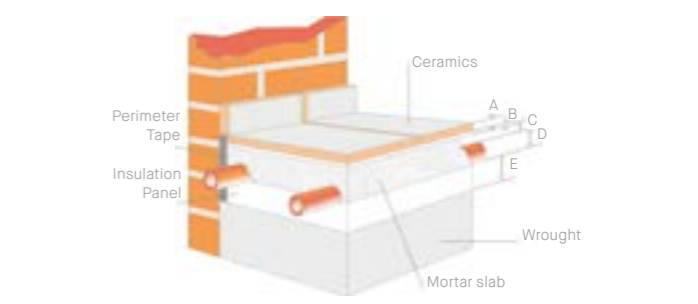

It is necessary to carry out laying of an unhardening perimeter joint, which usually consists of polythene, in order to avoid mechanical press being transmitted to walls from possible expansion or contraction. It is recommended to add a thin layer of poly-thene film, over 0.15 mm., between the insulation layer (E) and the mortar layer with the heating pipes (C-D) to increase warmth transmission performance in the desired direction. Moreover, PERONDA also recommends laying a thin polythene sheet between the mortar layer and the ceramic tile, which will perform as a waterproofing layer to compensate for the steam pressure which could be generated in case dampness would appear in the support structure as well as an unhardening layer over critical support structures. In case of laying on a surface bigger than 40 sqm. or length exceeding twice the room width, it is recommended to foresee additional dilatation joints with the same characteristics as the polythene perimeter joint.

PERONDA recommends carrying out a project made by a technical expert to ensure the proper working of this kind of installations, in case you would be interested in this type of building solution for heating.

## Technical information

### USE AND MAINTENANCE

How long a surface lasts will depend on the way it is used and maintained. Floor tile installation is never the last phase in a building project, and therefore it is necessary to protect newly tiled floors against possible damage by covering them with plastic or cardboard.

### ROUTINE CLEANING:

For the routine cleaning of floor tiles, in general normal neutral detergents should be used, never acid or abrasive ones, being sure to rinse the floor with clean water afterwards.

In the case of stubborn stains, commercial detergents can be used, always making sure to first check PERONDA's catalogue for the technical characteristics of the tiles in question, making sure they are resistant to chemical attack.

Certain types of grime (gravel, sand), increase the abrasive effect of people walking on tiles. Therefore, it is recommended to keep the tiled floor as clean as possible, making sure to protect the entry to areas exposed to traffic with doormats or rugs.

Ceramic floor tiles have a moderate degree of impact resistance. Therefore, in as much as possible, care should be taken to prevent heavy or sharp objects from falling on tiles in those areas of the home where this is most likely to occur.

### (FR) CONSEILS DE POSE

#### CONSEILS GÉNÉRAUX

1. Il est recommandé de niveler les surfaces avant d'appliquer les produits adhésifs (mortiers, mortiers colles, etc.).
2. Il est nécessaire de respecter les joints structurels, périmétriques et de dilatation.
3. Pour découper les pièces en grès cérame, il est conseillé d'employer une machine électrique refroidie à l'eau et des disques pour le grès cérame. Pour percer le grès cérame, puisqu'il s'agit d'un matériau très dur, il est nécessaire de procéder de la manière suivante:
  - 3.1.- Employer des mèches pour le grès cérame.
  - 3.2.- Ne pas activer le perceur de la perceuse.
  - 3.3.- Percer à faible régime.
  - 3.4.- Commencer avec une mèche fine puis percer ensuite avec la mèche finale.
  - 3.5.- Refroidir la mèche à l'eau pendant le perçage.
4. Éviter d'employer des produits abrasifs. Nettoyer à l'eau et au savon. Si l'un ou l'autre produit chimique est utilisé, nous recommandons d'effectuer un test à un endroit non visible. Consultez notre catalogue dans tous les cas.
5. Ne pas mouiller les pièces avant de les poser. Les pièces des produits rectifiés doivent toujours être posées sèches afin d'éviter le risque de déformation du matériau.
6. Avant la pose du produit rectifié, le mur doit être mis d'aplomb au moyen de mortier. Le temps minimum de durcissement de cette surface doit être de 2-3 jours.
7. Le mortier une fois totalement sec, le mortier colle doit être appliqué au moyen d'une taloche crantée. Il est nécessaire de respecter rigoureusement les instructions de gâchage et d'application indiquées par le fabricant sur l'emballage du produit lui-même.
8. Protéger les carreaux de sol contre un trafic prématuré pendant la phase de durcissement.
9. Toutes les pièces une fois posées et le mortier colle étant sec, procéder au jointoiment à l'aide du mortier de jointoiment et d'une taloche en caoutchouc. Il est nécessaire de respecter rigoureusement les instructions de gâchage et d'application indiquées par le fabricant sur l'emballage du produit lui-même.

#### POSE SUR DES SOLS ÉQUIPÉS D'UN SYSTÈME DE CHAUFFAGE RAYONNANT

En raison des phénomènes de transmission de chaleur et de dilatation/contraction auxquels le revêtement de sol peut être soumis, et qui sont inhérents à ces installations, il est recommandé de concevoir l'installation de la manière illustrée par la figure, les couches à appliquer et leurs épaisseurs estimées devant être les suivantes (voir légende):

- A) Carreaux de sol en céramique PERONDA (10 mm env.)
- B) Couche d'un mortier colle valable pour le type de carreaux de sol PERONDA acquis (5 mm env.)
- C) Couche de mortier pour y loger les tuyauteries de chauffage (40 mm env.)
- D) Tuyauteries de chauffage (noyées dans la couche de mortier)
- E) Couche d'isolation, normalement constituée par du polyéthylène et du polystyrène expansé (20 mm env.)

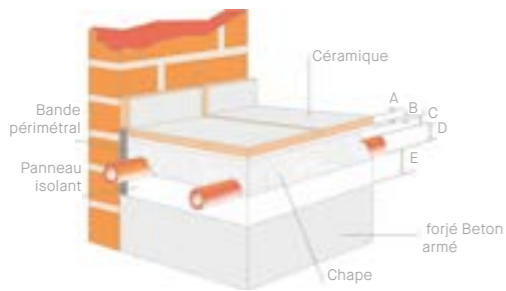

Il est nécessaire d'exécuter un joint périmétrique de désolidarisation, habituellement composé de polyéthylène, de manière à éviter que les dilatations ou

contractions possibles ne transmettent des contraintes mécaniques aux murs. Il est conseillé d'ajouter un film en polyéthylène d'environ 0,15 mm entre la couche d'isolation (E) et la couche de mortier contenant les tuyauteries (C-D), afin d'augmenter le rendement de la transmission de chaleur dans le sens souhaité. De la même manière, PERONDA recommande également de poser entre la couche de mortier et les carreaux céramiques une fine natte en polyéthylène faisant office de couche d'imperméabilisation, pour compenser la pression de vapeur qui pourrait être générée en cas d'apparition d'humidité dans le support, et comme couche de désolidarisation sur les supports critiques. Dans le cas des installations sur des surfaces supérieures à 40 m<sup>2</sup> ou si la longueur de la pièce d'habitation est supérieure au double de sa largeur, il est conseillé de prévoir des joints de dilatation additionnels possédant les mêmes caractéristiques que celles du joint périmétrique en polyéthylène.

Si ce type de solution de construction est souhaité pour le chauffage, PERONDA recommande de faire rédiger un projet par un technicien spécialisé, afin de garantir le fonctionnement correct de l'installation.

#### MISE EN SERVICE ET ENTRETIEN

La durée de conservation d'une surface dépend de la manière dont cette dernière est utilisée et entretenue. Le carreau de sol n'est jamais le dernier élément à installer sur le chantier : après avoir été posé, il est nécessaire qu'il soit protégé des agressions postérieures en étant recouvert de plastique ou de carton.

#### NETTOYAGE HABITUEL

Pour le nettoyage habituel des carreaux de sol, utiliser des détergents normaux généralement neutres, mais en aucun cas acides ou abrasifs, et rincer le revêtement de sol à l'eau propre au terme de l'opération.

Les taches persistantes éventuellement présentes peuvent être éliminées en utilisant des détergents du commerce, mais en prenant la précaution de consulter au préalable le catalogue de PERONDA en ce qui concerne les caractéristiques techniques du carreau en question, de manière à s'assurer qu'il résiste à l'attaque du produit chimique.

Certains types de salissures (graviers, sable) augmentent l'effet abrasif du piétinement des personnes. Il est par conséquent conseillé de conserver le sol aussi propre que possible en protégeant les entrées et les zones de passage à l'aide de paillassons.

Les carreaux céramiques présentent une résistance modérée aux coups. Il convient par conséquent d'éviter, dans la mesure du possible, toute chute d'objets lourds ou contondants dans les zones de la maison où ces chutes sont susceptibles de se produire.

### (GE) VERLEGETIPPS

#### ALLGEMEINE TIPPS

1. Es wird empfohlen, die Flächen vor dem Auftragen von Haftmaterial (Mörteln, Zementklebern usw.) entsprechend zu nivellieren.
2. Evtl. vorhandene Struktur-, Rand- und Dehnungsfugen müssen freigelassen werden.
3. Zum Schneiden von Feinsteinzeug wollte ein wassergekühlter elektrischer Scheibenschneider für Feinsteinzeug verwendet werden. Da Feinsteinzeug ein sehr hartes Material ist, müssen evtl. erforderliche Löcher folgendermaßen gebohrt werden:
  - 3.1.- Benutzen Sie Bohrer für Feinsteinzeug.
  - 3.2.- Zum Bohren nicht den Schlagbohrmodus aktivieren.
  - 3.3.- Mit geringer Umdrehungszahl bohren.
  - 3.4.- Mit einem dünnen Bohrer beginnen und anschließend die eigentlich erforderliche Bohrerstärke verwenden.
  - 3.5.- Während des Bohrens die Bohrspitze mit Wasser kühlen.
4. Verwenden Sie grundsätzlich keine scheuernden Produkte. Zum Reinigen sollte nur Wasser und Seife benutzt werden. Wenn Sie ein chemisches Mittel verwenden möchten, sollten Sie zuvor an einer wenig sichtbaren Stelle eine Probe machen. Lesen Sie auf jeden Fall zuvor in unserem Katalog nach.
5. Teile vor dem Verlegen nicht anfeuchten. Kalibrierte Teile werden immer trocken verlegt, um mögliche Formveränderungen des Materials zu vermeiden.
6. Vor dem Verlegen von kalibriertem Material muss die Wand begradigt, d. h., mit Mörtel lotrecht gemacht werden. Zum Abbinden dieser begradigten Fläche müssen mindestens 2-3 Tage vorgesehen werden.
7. Wenn der Mörtel vollständig trocken ist, wird der Zementkleber mit einem Zahnpachtel aufgetragen. Die Herstelleranweisungen auf der Verpackung zum Anmachen und Verlegen müssen genauestens befolgt werden.
8. Bodenbeläge müssen vor einer vorzeitigen Benutzung während der Abbindungszeit geschützt werden.
9. Wenn alle Teile verlegt sind und der Zementkleber getrocknet ist, wird zum Verfügen der Fugenmörtel mit einem Gummispachtel aufgetragen. Die Herstelleranweisungen auf der Verpackung zum Anmachen und Verlegen müssen genauestens befolgt werden.

### VERLEGUNG AUF BÖDEN MIT FUSSBODENHEIZUNG

Da sich derartige Bodenbeläge aufgrund der Wärmeübertragung ausdehnen und zusammenziehen können, wird empfohlen, die Verlegung so vorzunehmen, wie auf der Abbildung zu sehen ist, wobei die erforderlichen Schichten und deren ungefähre Dicke jeweils Folgende sind (siehe Angaben auf der Abbildung):

- A) Keramische Bodenfliesen PERONDA (ca. 10 mm).
- B) Schicht des für die Art der verwendeten Bodenfliesen von PERONDA geeigneten Zementklebers. (ca. 5 mm).
- C) Mörtelschicht, in der die Heizungsrohre untergebracht sind (ca. 40 mm).
- D) Heizungsrohre (innerhalb der Mörtelschicht).
- E) Isolierschicht, normalerweise aus expandiertem Polyethylen und Polystyrol (ca. 20 mm).

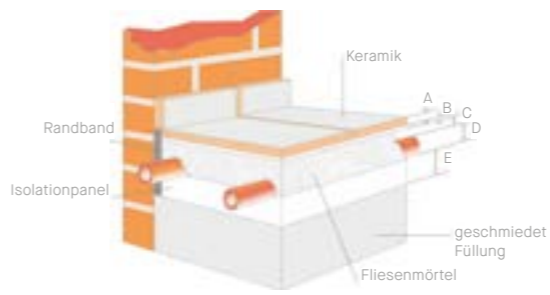

Zudem muss eine trennende Randfuge eingearbeitet werden, die normalerweise aus Polyethylen besteht, um zu verhindern, dass bei der Boden beim Ausdehnen oder Zusammenziehen mechanische Kräfte auf die Wände überträgt. Zwischen der Isolierschicht (E) und der Mörtelschicht mit den Heizungsrohren (C-D) sollte eine ca. 0,15 mm dicke Polyethylenfolie hinzugefügt werden, um den Wirkungsgrad der Wärmeübertragung in die gewünschte Richtung zu erhöhen. Zudem rät PERONDA, auf der Mörtelschicht und unter der Fliesenschicht eine dünne Polyethylenfolie anzubringen, die zur Abdichtung, zum Ausgleich von evtl. entstehendem Dampfdruck im Falle von Feuchtigkeit und als Trennschicht auf problematischen Untergründen dienen kann. Wenn die zu verlegende Bodenfläche größer als 40 m<sup>2</sup> beträgt, oder ihre Länge mehr als das Doppelte ihrer Breite ist, sollten zusätzliche Dehnungsfugen mit denselben Eigenschaften die die Randfuge aus Polyethylen vorgesehen werden.

PERONDA empfiehlt, im Falle derartiger baulicher Heizungslösungen von einem Fachmann ein entsprechendes Projekt ausarbeiten zu lassen, damit die Installation auch wirklich gut funktioniert.

#### BENUTZUNG UND PFLEGE

Die Haltbarkeit einer Fläche hängt davon ab, wie sie benutzt und gepflegt wird. Bei Bauarbeiten wird der Bodenbelag normalerweise nicht erst zum Schluss verlegt. Deshalb muss er nach dem Verlegen vor späteren Beschädigungen geschützt und gut mit Kunststoff oder Karton abgedeckt werden.

#### NORMALE REINIGUNG

Für die übliche Reinigung von Bodenfliesen können normale, im Allgemeinen neutrale, auf keinen Fall säurehaltige oder scheuernde Reinigungsmittel verwendet werden, zudem werden die Fliesen zum Abschluss mit sauberem Wasser gespült.

Bei nachhaltigen Flecken können handelsübliche Reinigungsmittel verwendet werden, dabei sollten jedoch zuvor im Katalog von PERONDA die technischen Eigenschaften der betreffenden Fliesen nachgelesen werden, um sicherzustellen, ob sie gegen chemische Produkte beständig sind.

Einige Schmutzarten (Kies, Sand) verstärken die Abriebwirkung beim Begehen. Deshalb sollten die Bodenfliesen immer so sauber wie möglich gehalten und Eingänge zu Durchgangsbereichen mit Abstreifern geschützt werden.

Keramische Bodenfliesen haben eine mäßige Widerstandsfähigkeit gegen Schläge. Deshalb muss in den Bereichen des Hauses, wo diese Gefahr besteht, so weit wie möglich verhindert werden, dass schwere oder spitze Gegenstände auf die Fliesen fallen.

### (RU) СОВЕТЫ ПО ОБЛИЦОВКЕ

#### ОБЩИЕ СОВЕТЫ

1. До нанесения раствора, клея, необходимо выровнять рабочую поверхность.
2. Необходимо следить за чёткостью структурных швов.
3. Резать керамогранит (porcelánico) рекомендуется только электрической машинкой с водным охлаждением и специальными дисками для керамогранита (porcelánico).
  - 3.1.- Пользоваться только сверлом для керамогранита (porcelánico).
  - 3.2.- Не применять пробойник в просверленном отверстии.
  - 3.3.- Сверлить на малых оборотах.
  - 3.4.- Начинать сверлить тонким сверлом и только затем – нужного диаметра, для завершения работы.

- 3.5.- Во время работы сверло периодически охлаждать водой.
4. Как правило, не применяются абразивные средства. Для очищения применяют воду и мыло. Если вы всё-таки решили попробовать какое-нибудь средство бытовой химии, то рекомендуем вам сделать это на менее видном месте. В любом случае, лучше воспользоваться советом в нашем каталоге.
5. Не мочить плитку перед облицовкой. Во избежание деформации, ректифицированная плитка должна укладываться сухой.
6. Перед облицовкой ректифицированной плиткой, на поверхность должен быть нанесён строительный раствор отвесным способом. Минимальный срок затвердения раствора 2-3 дня.
7. Когда стяжка высохнет, необходимо нанести клей зубчатым шпателем. Необходимо строго придерживаться инструкции производителя клея на упаковке.
8. Не допускать преждевременной эксплуатации покрытий в момент затвердения материала.
9. При завершении облицовки и высыхания клея/раствора, заполнять швы специальным раствором с помощью резинового шпателя. При этом строго следовать инструкции производителя на упаковке.

#### СОВЕТЫ ПО УКЛАДКЕ ПЛИТКИ НА ПОЛЫ С ПОДОГРЕВОМ

Из-за явлений теплопередачи и температурного расширения – сжатия, которые испытывает на себе напольное покрытие и которые являются неотъемлемой частью этих систем, рекомендуем производить укладку в соответствии с приведенными ниже рекомендациями и рисунком.

- A) Керамическое напольное покрытие PERONDA (~ 10 мм)
- B) Слой плиточного клея (~ 5 мм), соответствующего типу выбранного Вами материала PERONDA.
- C) Слой стяжки, который полностью покрывает трубы отопления. (~ 40 мм)
- D) Трубы отопления (находятся внутри слоя стяжки).
- E) Изоляционный слой, обычно состоит из композиции вспененных полиэтилена и полистирола. (~ 20 мм)



По периметру подогреваемой площади необходимо устроить компенсационный шов, обычно заполненный композицией из полиэтилена, чтобы предотвратить передачу механических усилий, возникающих при расширении – сжатии, на стены. Также рекомендуем между слоями E и D дополнительно проложить слой полиэтиленовой пленки толщиной около 0,15 мм для того, чтобы улучшить передачу тепла в желаемом направлении. Кроме того PERONDA рекомендует уложить слой тонкой полиэтиленовой пленки под плиточный клей для того, чтобы изолировать слой плитки и компенсировать давление водяных паров на случай проникновения влаги в слой цементной стяжки с трубами отопления. В случае, если «теплый пол» укладывается на площади > 40 м<sup>2</sup> или когда длина участка в 2 раза превышает ширину, то мы рекомендуем предусмотреть дополнительные швы температурного расширения с теми же характеристиками, что и периметральные швы с полиэтиленом.

PERONDA настоятельно рекомендует в случае необходимости укладки керамического материала на пол с подогревом и во избежание проблем и разочарования в будущем обращаться только к специалистам в этой области.

#### ИСПОЛЬЗОВАНИЕ И УХОД

Срок службы любой поверхности зависит от того, как ее используют и как за ней ухаживают. После укладки напольной плитки в том или ином помещении рабочим требуется ещё устанавливать предметы мебели, поэтому плитка должна быть защищена от повреждения с помощью пластика или картона.

#### ПЕРИОДИЧЕСКАЯ ОЧИСТКА

Для периодической очистки напольных покрытий могут использоваться норвежия обладают невысокой ударопрочностью. Это значит, что необходимо всеми силами избегать падения тяжелых или острых предметов, защищая покрытия в тех местах, где такие падения наиболее вероятны.

## alphabetical index

Artículo Item	Ref.	Tarifa price list	Formato Size (cm)	Formato Size (inch)	Pzs Caja pcs box	Peso Caja weight box	Pág.
<b>A</b> AGATHA-H/44/P	11320	M30	44x44	17 5/16x17 5/16	5	23,20	249
AGATHA-H/60/P	11892	M37	60x60	23 5/8x23 5/8	3	29,64	249
AGATHA-M/44/P	11322	M30	44x44	17 5/16x17 5/16	5	23,20	249
AGATHA-M/60/P	11921	M37	60x60	23 5/8x23 5/8	3	29,64	249
AVARIS/44/P	13453	M43	44x44	17 5/16x17 5/16	4	18,60	278
AVARIS/60/P	13375	M46	60x60	23 5/8x23 5/8	2	19,88	278
<b>B</b> BACH-M/P	8215	M37	60x60	23 5/8x23 5/8	3	29,64	266
BANSKY/P	9725	M43	44x44	17 5/16x17 5/16	5	23,20	299
BARDIGLIO GREY/60X120/EP	22059	M40	60x120	23 5/8x47 1/4	2	38,30	72
BARDIGLIO GREY/60X120/FLAM/R	22114	M66	60x120	23 5/8x47 1/4	2	38	72
BARDIGLIO GREY/60X120/RW/R	22113	M66	60x120	23 5/8x47 1/4	2	38	72
BARDIGLIO GREY/75,5X151/EP	21066	M58	75,5x151	29 3/4x59 7/16	1	30,70	72
BARDIGLIO GREY/75,5X151/RW/R	21072	M59	75,5x151	29 3/4x59 7/16	1	30,70	72
BARDIGLIO PEARL/60X120/EP	22060	M40	60x120	23 5/8x47 1/4	2	38,30	72
BARDIGLIO PEARL/60X120/FLAM/R	22115	M66	60x120	23 5/8x47 1/4	2	38	72
BARDIGLIO PEARL/60X120/RW/R	22112	M66	60x120	23 5/8x47 1/4	2	38	72
BARDIGLIO PEARL/75,5X151/EP	21067	M58	75,5x151	29 3/4x59 7/16	1	30,70	72
BARDIGLIO PEARL/75,5X151/RW/R	21073	M59	75,5x151	29 3/4x59 7/16	1	30,70	72
BASATI BIANCO/75,5X151/EP	21068	M58	75,5x151	29 3/4x59 7/16	1	30,70	109
BASATI BIANCO/75,5X151/NAT/R	21071	M59	75,5x151	29 3/4x59 7/16	1	30,70	109
<b>C</b> C.BEAUTY/P	11397	U77	18x60	7 1/16x23 5/8	4	11	267
C.ELENA-B/60/P	11834	U77	18x60	7 1/16x23 5/8	4	11	151
C.FONTAINE/44/P	11624	U69	10x44	3 15/16x17 5/16	4	4,40	250
C.GINA/P	10544	U52	4x44	1 9/16x17 5/16	28	11,12	278
C.GINGER-M/44/P	11602	U69	13x44	5 1/8x17 5/16	4	5,20	250
C.HETTANGIAN-B/90/EP	17335	U69	15x90	5 7/8x35 7/16	7	25,60	169
C.LOREN/P	8145	U52	4x44	1 9/16x17 5/16	28	11,12	260
C.LUXURY-N/P	9904	U68	10x44	3 15/16x17 5/16	12	12,20	283
C.METROPOLITAN-B/90/EP	17370	U69	15x90	5 7/8x35 7/16	7	25,60	187
C.MUSA/1/44/P	13221	U87	22x44	8 11/16x17 5/16	8	17,40	278
C.MUSA/1/60/P	13442	U72	22x60	8 11/16x23 5/8	4	12,60	278
C.MUSA/2/44/P	13222	U62	22x44	8 11/16x17 5/16	8	17,40	278
C.MUSA/2/60/P	13443	U64	22x60	8 11/16x23 5/8	4	12,60	278
C.ORIENT-N/P	9867	U64	13,5x44	5 5/16x17 5/16	4	6	283
C.SOFIA/60/P	10137	U85	7x60	2 3/4x23 5/8	14	12,10	260
C.SOFIA/P	8146	U61	7x44	2 3/4x17 5/16	14	10	260
CALACATTA EXTRA WHITE/100X100/EP	24206	M76	100x100	39 3/8x39 3/8	2	36,80	19
CALACATTA EXTRA WHITE/100X100/NAT/R	23977	M75	100x100	39 3/8x39 3/8	2	36,80	19
CALACATTA EXTRA WHITE/100X180/EP	24203	M76	100x180	39 3/8x70 7/8	2	66,07	19
CALACATTA EXTRA WHITE/100X180/NAT/R	23211	M75	100x180	39 3/8x70 7/8	2	66,07	19
CAPITAL-B/60/P	16745	M37	60x60	23 5/8x23 5/8	3	29,64	255
CARTAGO-B/44/P	13439	M43	44x44	17 5/16x17 5/16	4	18,60	278
CARTAGO-M/44/P	13451	M43	44x44	17 5/16x17 5/16	4	18,60	272
<b>D</b> D.BARDIGLIO GREY MOSAIC/30X30	22249	U58	30x30	11 13/16x11 13/16	8	15,64	73
D.BARDIGLIO PEARL MOSAIC/30X30	22250	U58	30x30	11 13/16x11 13/16	8	15,64	73
D.BASATI BIANCO MOSAIC/30X30	22251	U58	30x30	11 13/16x11 13/16	8	15,64	109
D.FIDIAS-B/5/EP	19548	U49	29,9x29,9	11 3/4x11 3/4	8	15	151
D.GIOIA GOLD/5/EP	19661	U49	29,9x29,9	11 3/4x11 3/4	8	15	161
D.GIOIA SILVER/5/EP	19662	U49	29,9x29,9	11 3/4x11 3/4	8	15	161
D.GREVIN-H/5/EP	19547	U49	29,9x29,9	11 3/4x11 3/4	8	15	211
D.GREYSTONE ARGENT MOSAIC/30X30/EP	23539	U58	30x30	11 13/16x11 13/16	8	15,64	81
D.GREYSTONE SMOKE MOSAIC/30X30/EP	23540	U58	30x30	11 13/16x11 13/16	8	15,64	81
D.HETTANGIAN-B/90/1/EP	17546	U72	90x90	35 7/16x35 7/16	1	21,48	169
D.HETTANGIAN-G/5/EP	19546	U49	29,9x29,9	11 3/4x11 3/4	8	15	169
D.HETTANGIAN-I/5/EP	19545	U49	29,9x29,9	11 3/4x11 3/4	8	15	169
D.LILINOIS-B/60/EP	17634	U70	60x60	23 5/8x23 5/8	3	24,59	187
D.LENS GREY BRICK/29,8X29,2/RW	22793	U50	29,8x29,2	11 1/2x11 3/4	8	12,20	221
D.LENS GREY MOSAIC/30X30/RW	22778	U39	30x30	11 13/16x11 13/16	8	15,64	221
D.LENS SILVER BRICK/29,8X29,2/RW	22792	U50	29,8x29,2	11 1/2x11 3/4	8	12,20	221
D.LENS SILVER MOSAIC/30X30/RW	22779	U39	30x30	11 13/16x11 13/16	8	15,64	221
D.LENS TAUPÉ BRICK/29,8X29,2/RW	22791	U50	29,8x29,2	11 1/2x11 3/4	8	12,20	221
D.LENS TAUPÉ MOSAIC/30X30/RW	22777	U39	30x30	11 13/16x11 13/16	8	15,64	221
D.LENS WHITE BRICK/29,8X29,2/RW	22790	U50	29,8x29,2	11 1/2x11 3/4	8	12,20	221
D.LENS WHITE MOSAIC/30X30/RW	22776	U39	30x30	11 13/16x11 13/16	8	15,64	221
D.LUMINA-B/5/EP	19549	U49	29,9x29,9	11 3/4x11 3/4	8	15	225
D.MACBA-M/1/P	10142	U61	60x60	23 5/8x23 5/8	3	25,26	260
D.MARQUINA BLACK MOSAIC/30X30/EP	23542	U58	30x30	11 13/16x11 13/16	8	15,64	91
D.METROPOLITAN-B/5	17696	U49	29,9x29,9	11 3/4x11 3/4	8	15	187
D.METROPOLITAN-B/90/1/EP	17547	U72	90x90	35 7/16x35 7/16	1	21,48	187

Artículo Item	Ref.	Tarifa price list	Formato Size (cm)	Formato Size (inch)	Pzs Caja pcs box	Peso Caja weight box	Pág.
<b>D</b> D.MUVIM-M-1/P	10309	U66	44x44	17 5/16x17 5/16	4	16,09	260
D.MUVIM-M-4/P	9318	U82	88x88	34 5/8x34 5/8	1	21,20	260
D.NARA PEARL MOSAIC/30X30	22247	U58	30x30	11 13/16x11 13/16	8	15,64	117
D.NARA WHITE MOSAIC/30X30	22248	U58	30x30	11 13/16x11 13/16	8	15,64	117
D.RUGBY BLACK BRICK/29,8X29,2/EP	23554	U51	29,8x29,2	11 1/2x11 3/4	8	12,20	41
D.RUGBY BLACK BRICK/29,8X29,2/NAT	23555	U50	29,8x29,2	11 1/2x11 3/4	8	12,20	41
D.RUGBY BLACK MOSAIC/25X25/EP	23550	U44	25x25	9 13/16x9 13/16	8	7,74	41
D.RUGBY BLACK MOSAIC/25X25/NAT	23551	U39	25x25	9 13/16x9 13/16	8	7,74	41
D.RUGBY GREY BRICK/29,8X29,2/EP	23553	U51	29,8x29,2	11 1/2x11 3/4	8	12,20	41
D.RUGBY GREY BRICK/29,8X29,2/NAT	23556	U50	29,8x29,2	11 1/2x11 3/4	8	12,20	41
D.RUGBY GREY MOSAIC/25X25/EP	23549	U39	25x25	9 13/16x9 13/16	8	7,74	41
D.RUGBY GREY MOSAIC/25X25/NAT	23552	U44	25x25	9 13/16x9 13/16	8	7,74	41
D.SOLTO BLACK BRICK/29,8X29,2/EP	22755	U51	29,8x29,2	11 1/2x11 3/4	8	12,20	53
D.SOLTO BLACK BRICK/29,8X29,2/RW	22759	U50	29,8x29,2	11 1/2x11 3/4	8	12,20	53
D.SOLTO BLACK MOSAIC/25X25/EP	22747	U44	25x25	9 13/16x9 13/16	8	7,74	53
D.SOLTO BLACK MOSAIC/25X25/RW	22751	U39	25x25	9 13/16x9 13/16	8	7,74	53
D.SOLTO GREY BRICK/29,8X29,2/EP	22754	U51	29,8x29,2	11 1/2x11 3/4	8	12,20	53
D.SOLTO GREY BRICK/29,8X29,2/RW	22758	U50	29,8x29,2	11 1/2x11 3/4	8	12,20	53
D.SOLTO GREY MOSAIC/25X25/EP	22746	U44	25x25	9 13/16x9 13/16	8	7,74	53
D.SOLTO GREY MOSAIC/25X25/RW	22750	U39	25x25	9 13/16x9 13/16	8	7,74	53
D.SOLTO SAND BRICK/29,8X29,2/EP	22752	U51	29,8x29,2	11 1/2x11 3/4	8	12,20	53
D.SOLTO SAND BRICK/29,8X29,2/RW	22756	U50	29,8x29,2	11 1/2x11 3/4	8	12,20	53
D.SOLTO SAND MOSAIC/25X25/EP	22743	U44	25x25	9 13/16x9 13/16	8	7,74	53
D.SOLTO SAND MOSAIC/25X25/RW	22748	U39	25x25	9 13/16x9 13/16	8	7,74	53
D.SOLTO TAUPÉ BRICK/29,8X29,2/EP	22753	U51	29,8x29,2	11 1/2x11 3/4	8	12,20	53
D.SOLTO TAUPÉ BRICK/29,8X29,2/RW	22757	U50	29,8x29,2	11 1/2x11 3/4	8	12,20	53
D.SOLTO TAUPÉ MOSAIC/25X25/EP	22745	U44	25x25	9 13/16x9 13/16	8	7,74	53
D.SOLTO TAUPÉ MOSAIC/25X25/RW	22749	U39	25x25	9 13/16x9 13/16	8	7,74	53
D.STATUARIO PLUS MOSAIC/30X30/EP	23541	U58	30x30	11 13/16x11 13/16	8	15,64	99
D.STONE MIX ARR./16X25/EP	23537	U49	16x25	3 15/16x10 1/4	16	6,6	81
D.SUITE BEIGE MIX ARR./16X25/EP	22774	U49	16x25	3 15/16x10 1/4	16	6,60	137
D.SUITE BEIGE MOSAIC/30X30/EP	22740	U58	30x30	11 13/16x11 13/16	8	15,64	137
D.SUITE BLACK MOSAIC/30X30/EP	22739	U58	30x30	11 13/16x11 13/16	8	15,64	137
D.SUITE BROWN MOSAIC/30X30/EP	22741	U58	30x30	11 13/16x11 13/16	8	15,64	137
D.SUITE PEARL MIX ARR./16X25/EP	22775	U49	16x25	3 15/16x10 1/4	16	6,60	137
D.SUITE PEARL MOSAIC/30X30/EP	22742	U58	30x30	11 13/16x11 13/16	8	15,64	137
D.SUNSHINE-B/5/EP	19550	U49	29,9x29,9	11 3/4x11 3/4	8	15	207
D.TORANO BIANCO MOSAIC/30X30	22252	U58	30x30	11 13/16x11 13/16	8	15,64	145
DEEP BLACK/100X100/EP	24205	M76	100x100	39 3/8x39 3/8	2	36,80	25
DEEP BLACK/100X100/NAT/R	23975	M75	100x100	39 3/8x39 3/8	2	36,80	25
DEEP BLACK/100X180/EP	24201	M76	100x180	39 3/8x70 7/8	2	66,07	25
DEEP BLACK/100X180/NAT/R	23973	M75	100x180	39 3/8x70 7/8	2	66,07	25
<b>E</b> E.BEAUTY/P	11398	U52	18x18	7 1/16x17 5/16	4	3,40	267
E.D.FONTAINE/44/P	11590	U90	44x44	17 5/16x17 5/16	4	18,20	250
E.D.LUXURY-N/P	9903	U80	44x44	17 5/16x17 5/16	4	19	283
E.ELENA-B/60/P	11833	U52	18x18	7 1/16x17 5/16	4	3,40	151
E.FONTAINE/44/P	11623	U60	10x10	3 15/16x3 15/16	8	2	250
E.GINGER-M/44/P							

## alphabetical index

Artículo Item	Ref.	Tarifa price list	Formato Size (cm)	Formato Size (inch)	Pzs Caja pcs box	Peso Caja weight box	Pág.
S SUITE PEARL/75,5X151/EP	22126	M58	75,5x151	29 3/4x59 7/16	1	30,70	136
SUNSHINE-B/60X120/EP	18495	M40	60x120	23 5/8x47 1/4	2	38,30	207
SUNSHINE-B/90X90/EP	18669	M2	90x90	35 7/16x35 7/16	1	22,25	207
T T.FIDIAS-B/5/P	11882	U11	5x5	1 15/16x1 15/16	40	2,60	151
T.GINA/P	10546	U64	4x4	1 9/16x1 9/16	10	0,80	278
T.I.GINA/P	10543	U70	29x29	11 7/16x11 7/16	3	4,64	278
T.I.HETTANGIAN-B/90/EP	17338	U75	41x41	16 1/8x16 1/8	4	14,20	169
T.I.METROPOLITAN-B/90/EP	17372	U75	41x41	16 1/8x16 1/8	4	14,20	187
T.I.SOFIA/P	8143	U70	29x29	11 7/16x11 7/16	3	4,64	260
T.LOREN/P	8468	U64	4x4	1 9/16x1 9/16	10	0,80	260
T.LUXURY-N/60/P	11883	U11	5x5	1 15/16x1 15/16	40	2,60	151
T.LUXURY-N/P	10675	U8	3x3	1 3/16x1 3/16	40	1,01	283
T.PERSEPOLIS-M/44/P	13190	U8	3x3	1 3/16x1 3/16	40	2,45	272
T.PERSEPOLIS-M/60/P	13189	U11	5x5	1 15/16x1 15/16	40	2,28	272
T.SOFIA/P	8147	U69	7x7	2 3/4x2 3/4	10	1,30	260
TORANO BIANCO/60X120/EP	22011	M40	60x120	23 5/8x47 1/4	2	38,30	144
TORANO BIANCO/60X120/NAT/R	22012	M66	60x120	23 5/8x47 1/4	2	38	144
TORANO BIANCO/75,5X151/EP	21070	M58	75,5x151	29 3/4x59 7/16	1	30,70	144
TORANO BIANCO/75,5X151/NAT/R	21074	M59	75,5x151	29 3/4x59 7/16	1	30,70	144
TORANO BIANCO/90X90/EP	22061	M2	90x90	35 7/16x35 7/16	1	22,25	144
TORANO BIANCO/90X90/NAT/R	22062	M68	90x90	35 7/16x35 7/16	1	21	144
TRAP.GREYSTONE ARGENT/34,5X15/EP	23558	U28	34,5x15	5 7/8x13 9/16	10	15,20	81

Artículo Item	Ref.	Tarifa price list	Formato Size (cm)	Formato Size (inch)	Pzs Caja pcs box	Peso Caja weight box	Pág.
T TRAP.GREYSTONE ARGENT/34,5X15/NAT	23683	U28	34,5x15	5 7/8x13 9/16	10	15,20	81
TRAP.GREYSTONE SMOKE/34,5X15/EP	23562	U28	34,5x15	5 7/8x13 9/16	10	15,20	81
TRAP.GREYSTONE SMOKE/34,5X15/NAT	23684	U28	34,5x15	5 7/8x13 9/16	10	15,20	81
TRAP.MARQUINA BLACK/34,5X15/EP	23563	U28	34,5x15	5 7/8x13 9/16	10	15,20	91
TRAP.MARQUINA BLACK/34,5X15/NAT	23686	U28	34,5x15	5 7/8x13 9/16	10	15,20	91
TRAP.STATUARIO PLUS/34,5X15/EP	23564	U28	34,5x15	5 7/8x13 9/16	10	15,20	99
TRAP.STATUARIO PLUS/34,5X15/NAT	23685	U28	34,5x15	5 7/8x13 9/16	10	15,20	99
TRI.GREYSTONE ARGENT/17,2X15/EP	23557	U13	17,2x15	5 7/8x6 3/4	30	15,20	81
TRI.GREYSTONE ARGENT/17,2X15/NAT	23687	U13	17,2x15	5 7/8x6 3/4	30	15,20	81
TRI.GREYSTONE SMOKE/17,2X15/EP	23559	U13	17,2x15	5 7/8x6 3/4	30	15,20	81
TRI.GREYSTONE SMOKE/17,2X15/NAT	23688	U13	17,2x15	5 7/8x6 3/4	30	15,20	81
TRI.MARQUINA BLACK/17,2X15/EP	23560	U13	17,2x15	5 7/8x6 3/4	30	15,20	91
TRI.MARQUINA BLACK/17,2X15/NAT	23689	U13	17,2x15	5 7/8x6 3/4	30	15,20	91
TRI.STATUARIO PLUS/17,2X15/EP	23561	U13	17,2x15	5 7/8x6 3/4	30	15,20	99
TRI.STATUARIO PLUS/17,2X15/NAT	23690	U13	17,2x15	5 7/8x6 3/4	30	15,20	99
TUCCI BLACK/60X120/P	20387	M46	60x120	23 5/8x47 1/4	2	39,62	240
TUCCI BLACK/60X60/P	20577	M37	60x60	23 5/8x23 5/8	3	29,64	240
TUCCI GOLD/60X120/P	20388	M46	60x120	23 5/8x47 1/4	2	39,62	240
TUCCI GOLD/60X60/P	20578	M37	60x60	23 5/8x23 5/8	3	29,64	240
V VOGUE-B/120/P	12949	M46	60x120	23 5/8x47 1/4	2	39,62	245
Z ZAR-M/P	6427	M30	44x44	17 5/16x17 5/16	5	23,20	266

## ICONOGRAPHY

	V1	Variación en tonalidad uniforme	Uniform shade	Variation de tons uniforme	Einheitliche Farbtonunterschiede	Общая вариация по тональности
	V2	Variación en tonalidad ligera	Slight shade variation	Variation de tons légère	Leichte Farbtonunterschiede	Легкая вариация по тональности
	V3	Variación en tonalidad media	Medium shade variation	Variation de tons moyenne	Mittlere Farbtonunterschiede	Средняя вариация по тональности
	V4	Variación en tonalidad pronunciada	Pronounced shade variation	Variation de tons prononcée	Starke Farbtonunterschiede	Сильная вариация по тональности
	Mate	Matte	Mat	Matt	матовая	
	Brillo	Gloss	Brillant	Glänzend	глянец	
	Malla	Mesh	Maille	Auf Netz	декоративный элемент на сетке	
	Decorados y bases producidos con metales preciosos y/o esmaltes reactivos. Limpiar con productos de PH neutros y sin abrasivos	Decors produced with precious metals and/or reactive glazes. That is why they have to be cleaned with neutral and non-abrasive products	Decors fabriqués avec métaux précieux et/ou émaux réactifs. Nettoyer avec produits neutres et sans abrasifs	Dekorationen mit Metallanteilen. Achtung, nicht mit säurehaltigen Reinigern pflegen	декоративные элементы произведенные с нанесением ценных металлов и реактивных эмалей на поверхность декоров. После жат чистке только при помощи нейтральных чистящих средств, которые не содержат абразивных микрочастиц	
	Vidrio	Glass	Verre	Glas	Стекло	
	Revestimiento	Wall tiles	Revêtement	Wandfliesen	только настенная	
	Metal	Metal	Métal	Metall	Металл	

All colours and hues appearing in this catalogue should be considered approximate, only in view of the printing processes involved. The rights of all contents (texts, photographs, drawings, designs, etc.) of this catalogue remain the property of PERONDA GROUP, S.A (or, failing that, they have the corresponding permissions and authorizations of the owners). No part of this publication may be reproduced, stored in a retrieval system, or transmitted in any form or by any means, electronic, mechanical, photocopying, recording or otherwise, without the prior written permission of the copyright holders.

Debido a los procesos de impresión, los colores que aparecen en este catálogo deben considerarse aproximados, y no exactos. Los derechos de todos los contenidos (textos, fotografías, dibujos, diseños etc) del presente catálogo son propiedad de PERONDA GROUP, S.A (o en su defecto, cuentan con los correspondientes permisos y autorizaciones de sus titulares). No está permitida la reproducción total o parcial de esta publicación, ni su tratamiento informático, ni la transmisión de ninguna forma o por cualquier medio, ya sea electrónico, mecánico, por fotocopia, por registro u otros medios, sin el permiso previo y por escrito de los titulares del copyright.

# MUSEUM

© PERONDA GROUP 2018  
Av. Manuel Escobedo, 26.  
12200 Onda (Castellón) España



[museumsurfaces.com](http://museumsurfaces.com)